

Matematyka stosowana

Zastosowania geometrii wykreślnej w praktyce inżynierskiej

2. Projektowanie placów i dróg dojazdowych

dr inż. arch. Anna Wanclaw

Politechnika Gdańska, Wydział Architektury

Studia inżynierskie, kierunek Gospodarka przestrzenna, semestr III

2. Projektowanie placów i dróg dojazdowych

- Projektowanie łuków pionowych drogi

Wokół poziomego placu i drogi dojazdowej założyć skarpy wykopów i nasypów, wyznaczyć ich krawędzie przecięcia się z terenem.

Zaprojektować łagodne przejście z placu w drogę zakładając powierzchnię walcową o promieniu 35 m.

- nachylenie drogi = 15%
- nachylenie skarpy nasypu = 2/3
- nachylenie skarpy wykopu = 4/3
- promień krzywizny pionowej = 35m

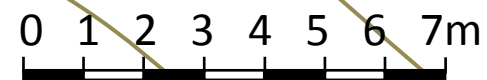
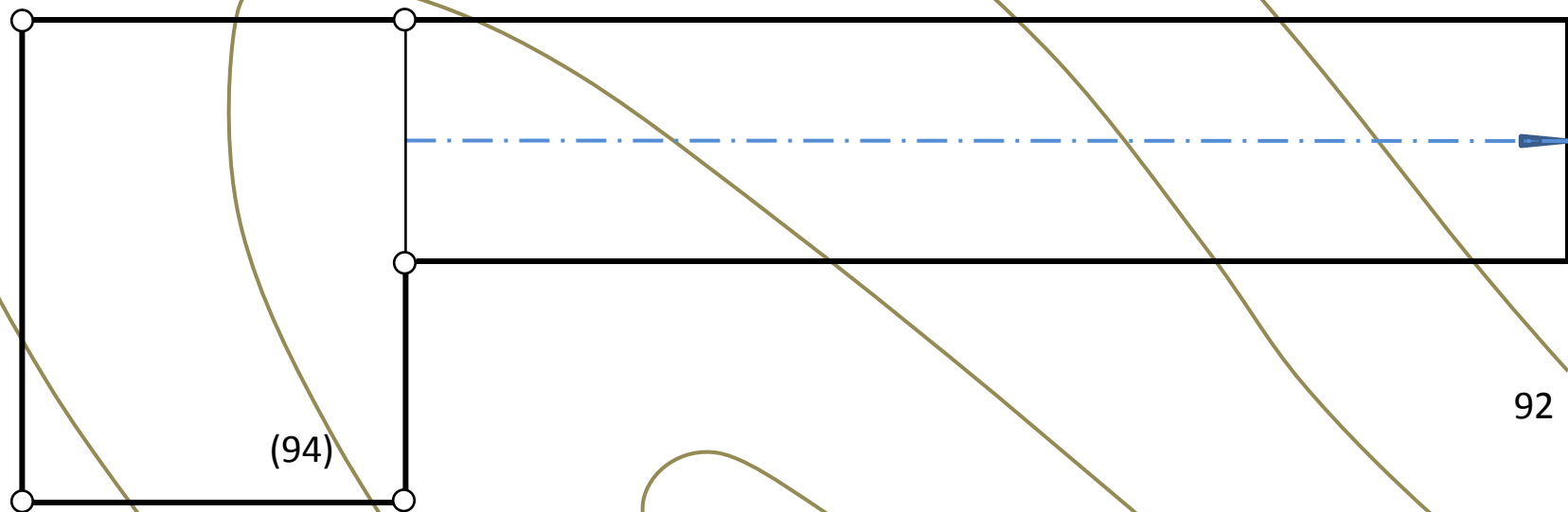

93

92

91

90

89

88

89

90

91

92

93

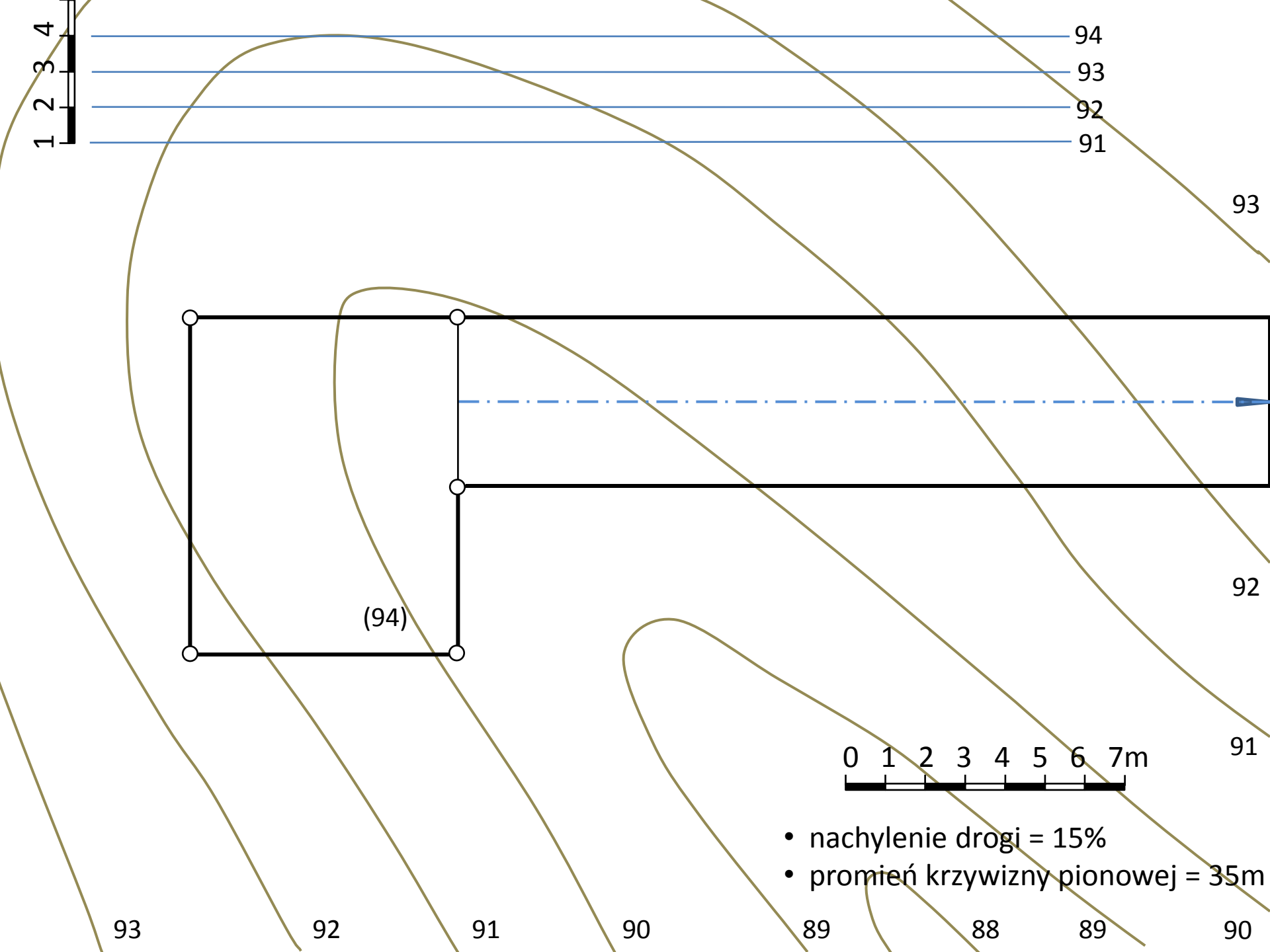

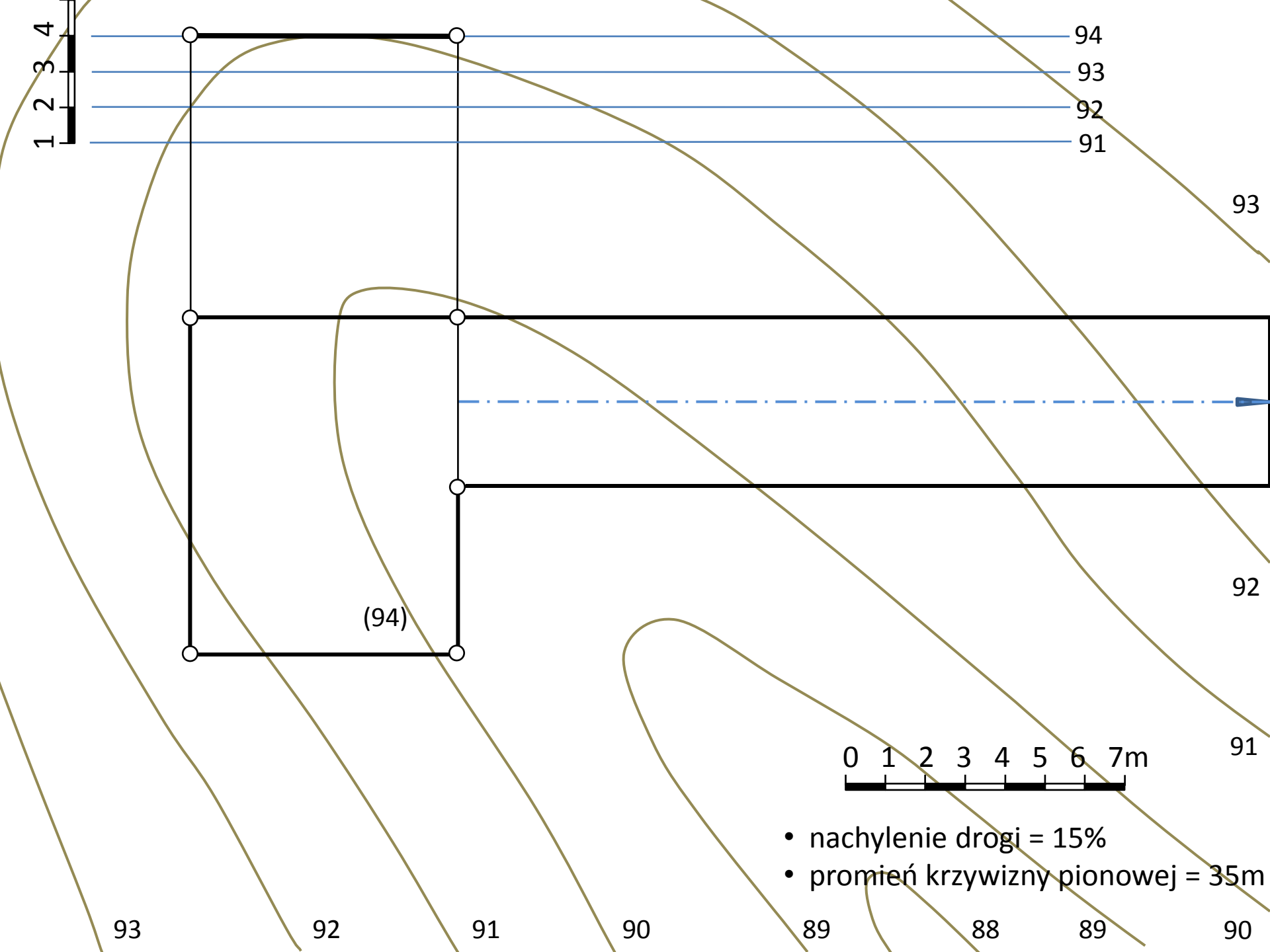

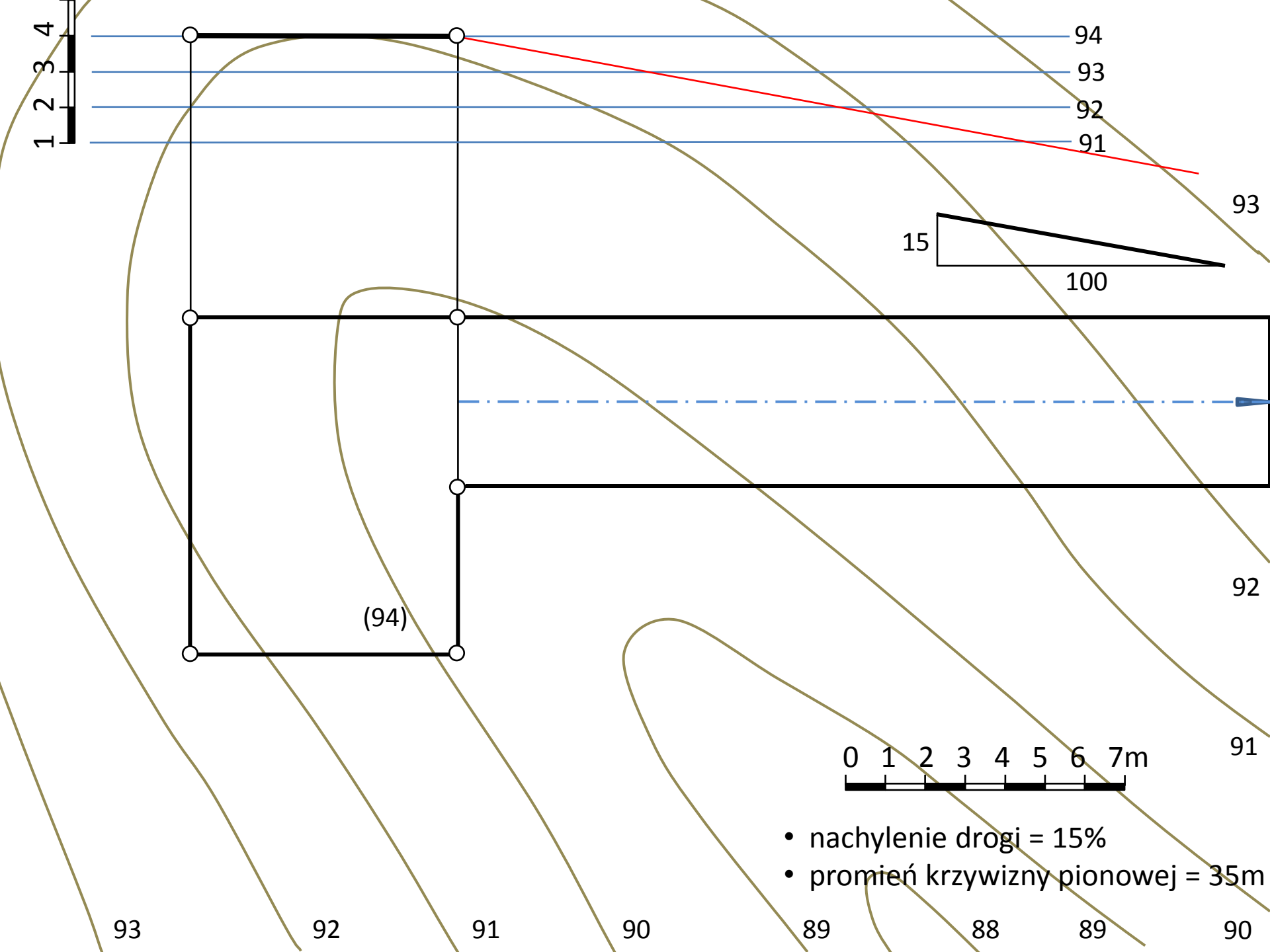

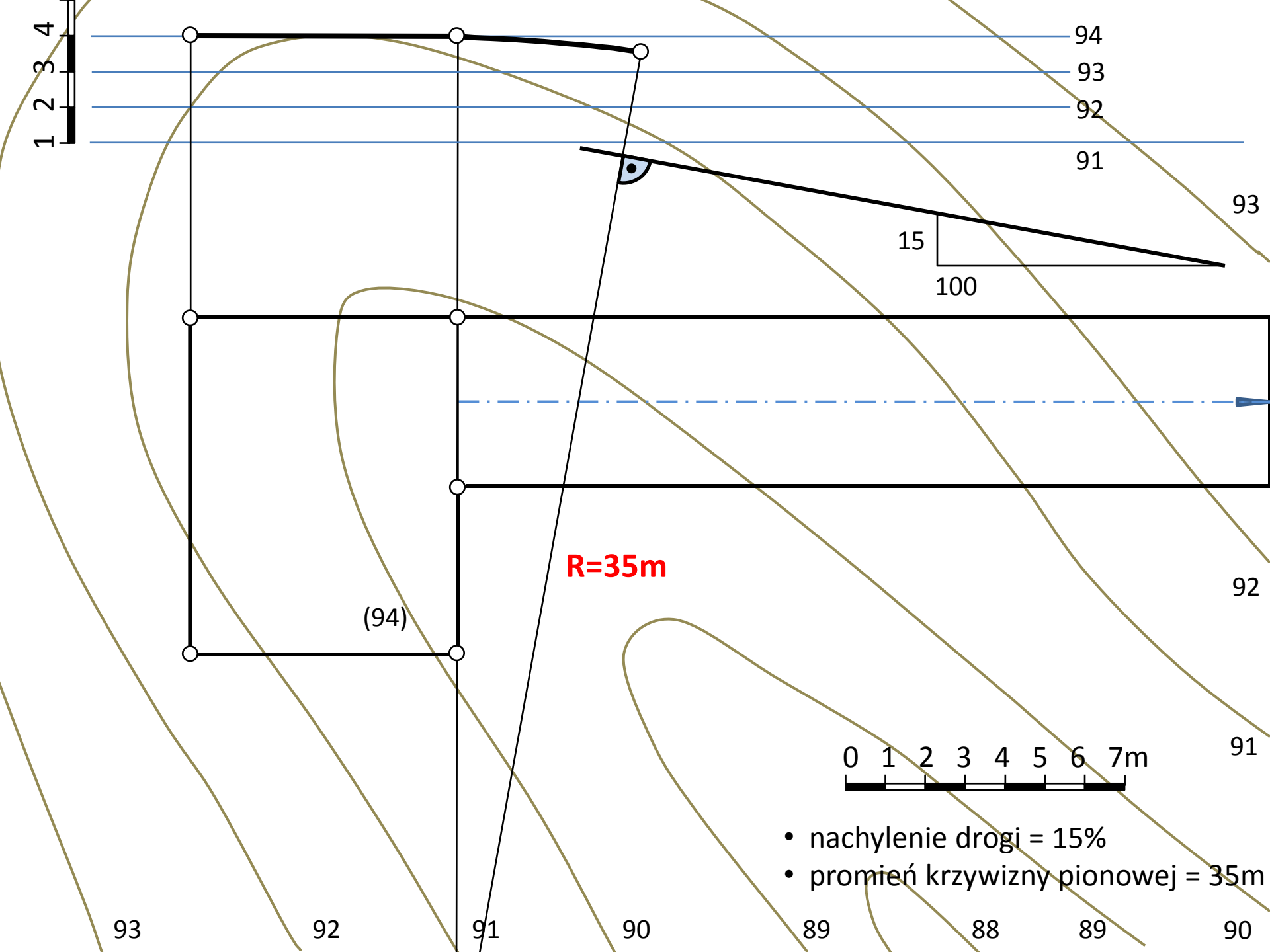

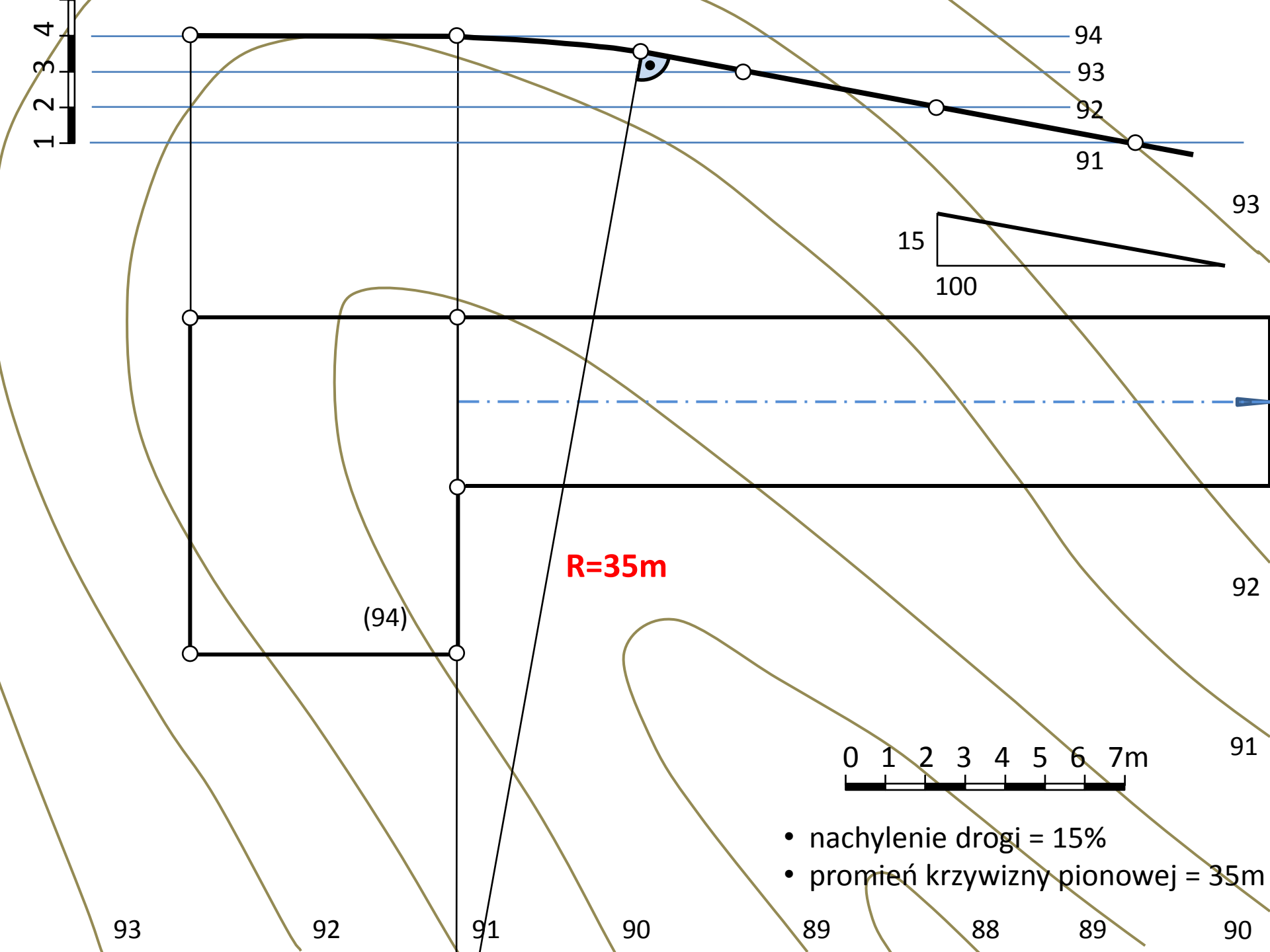

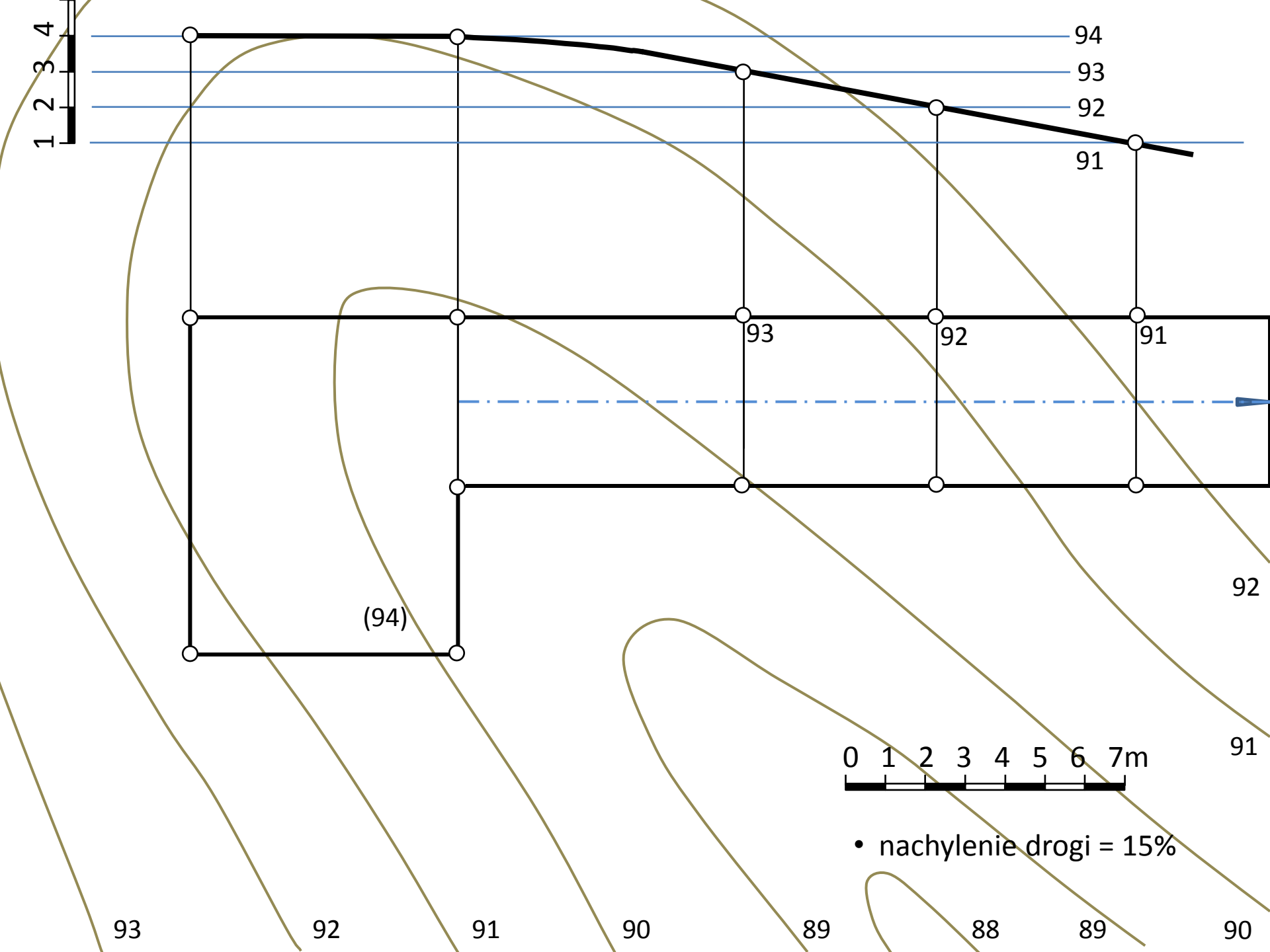

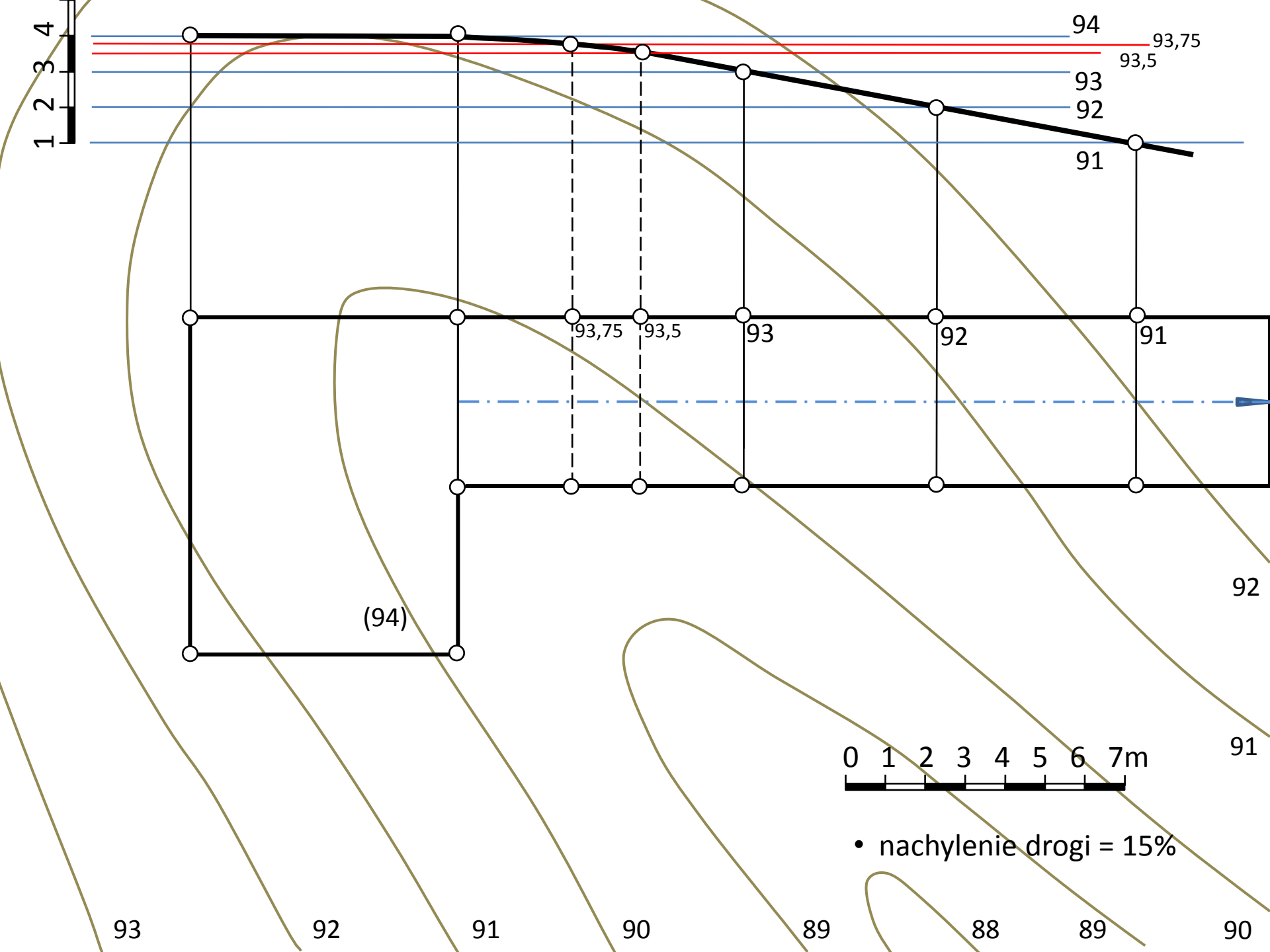

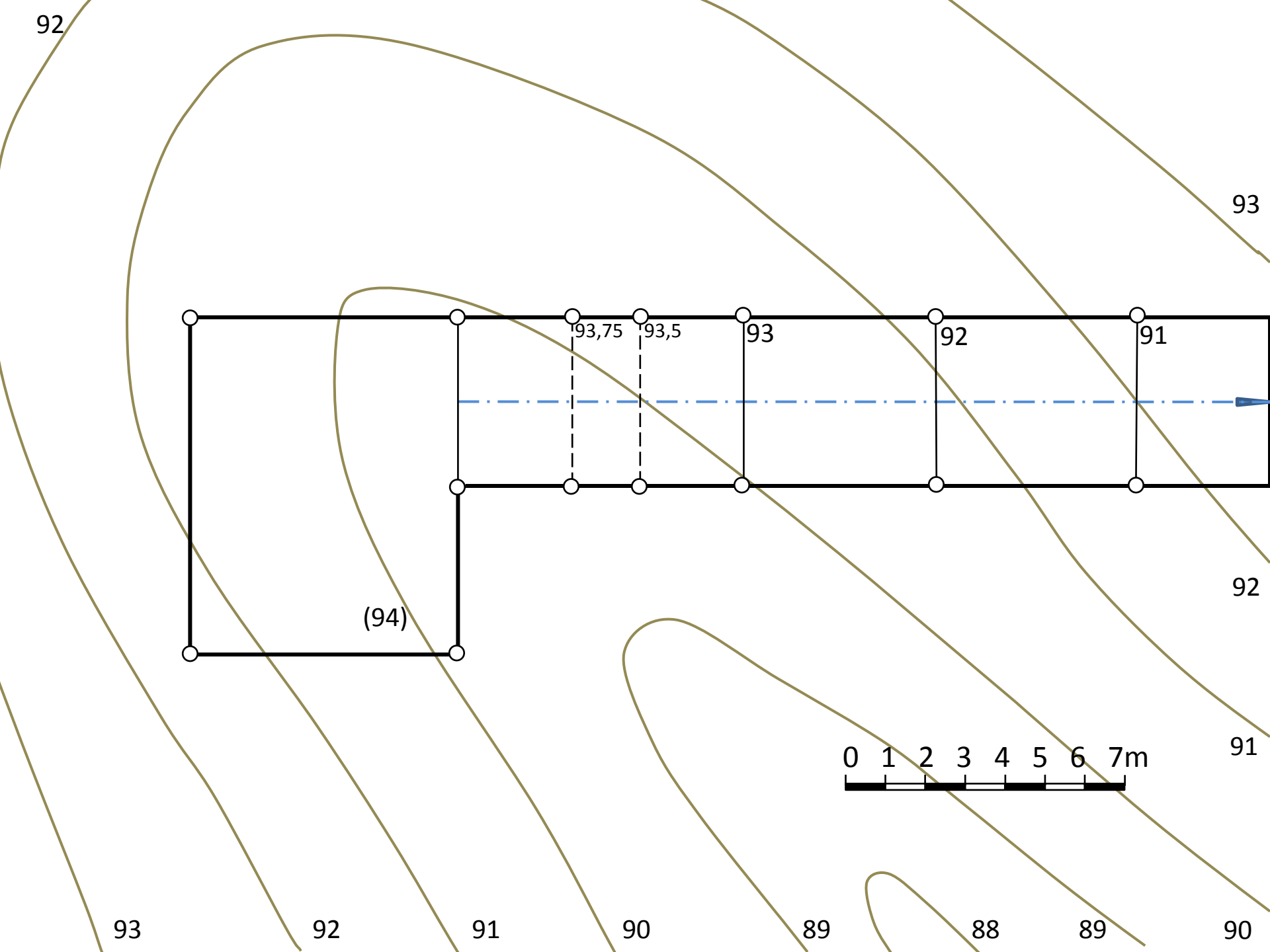

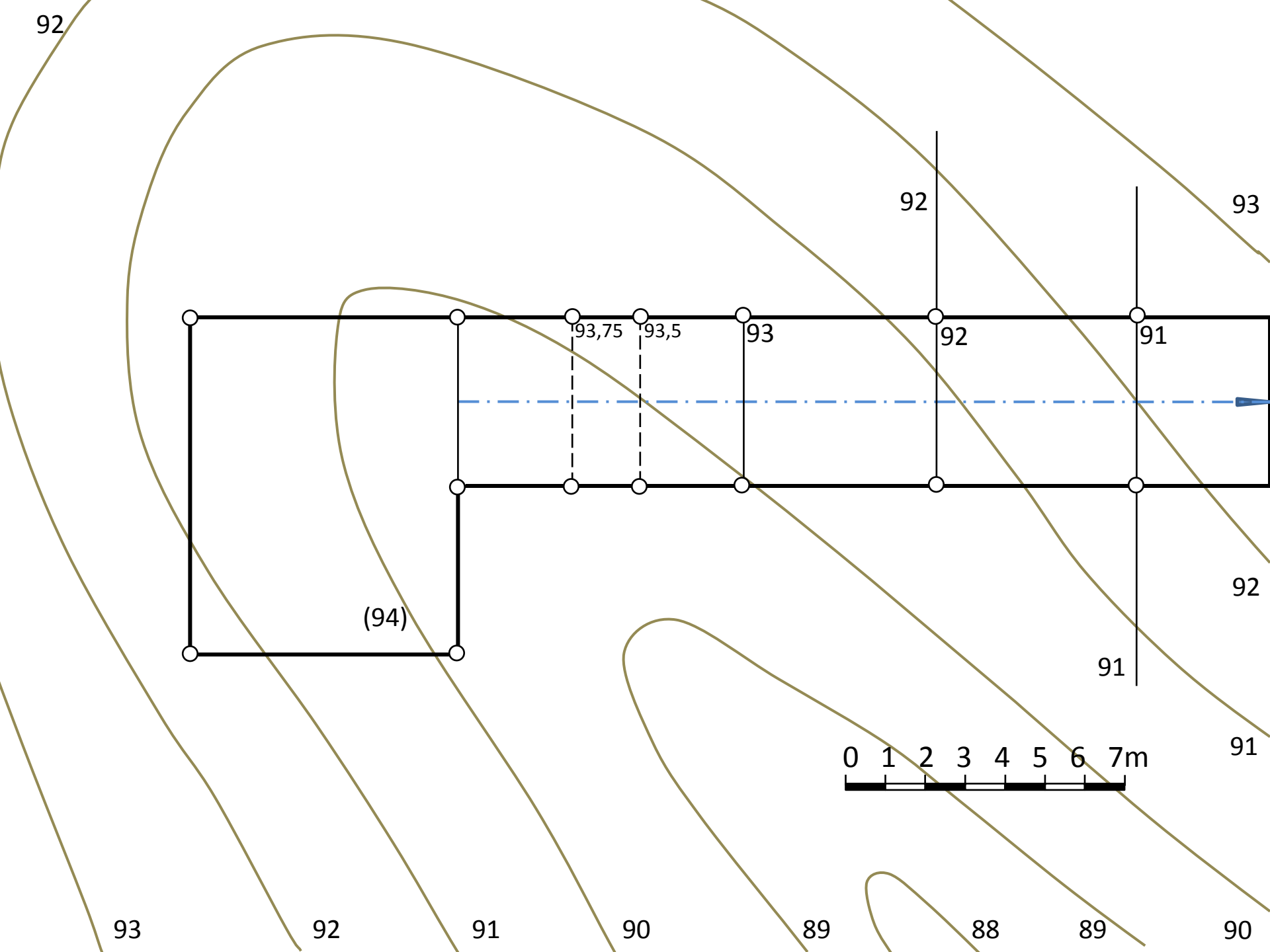

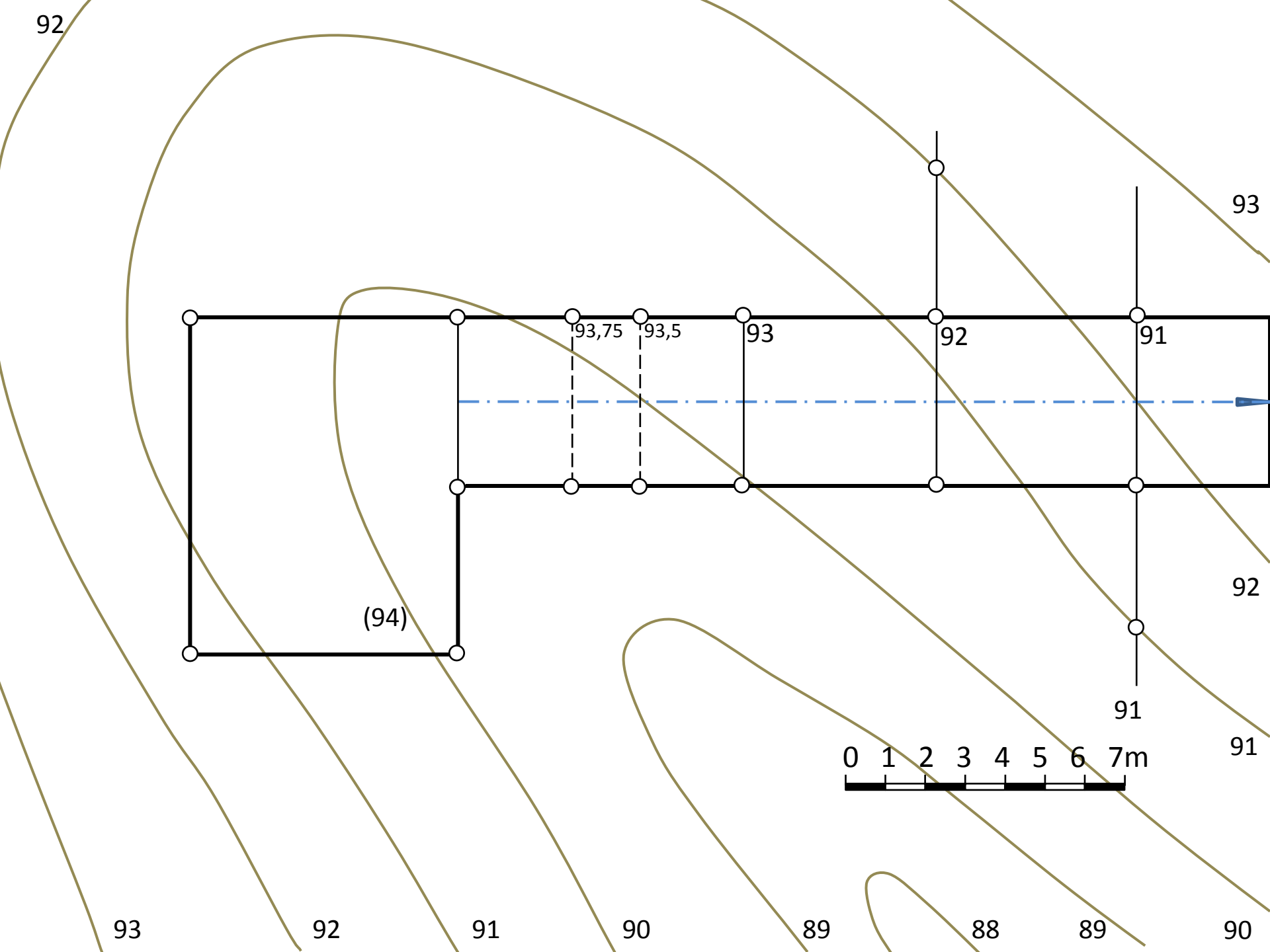

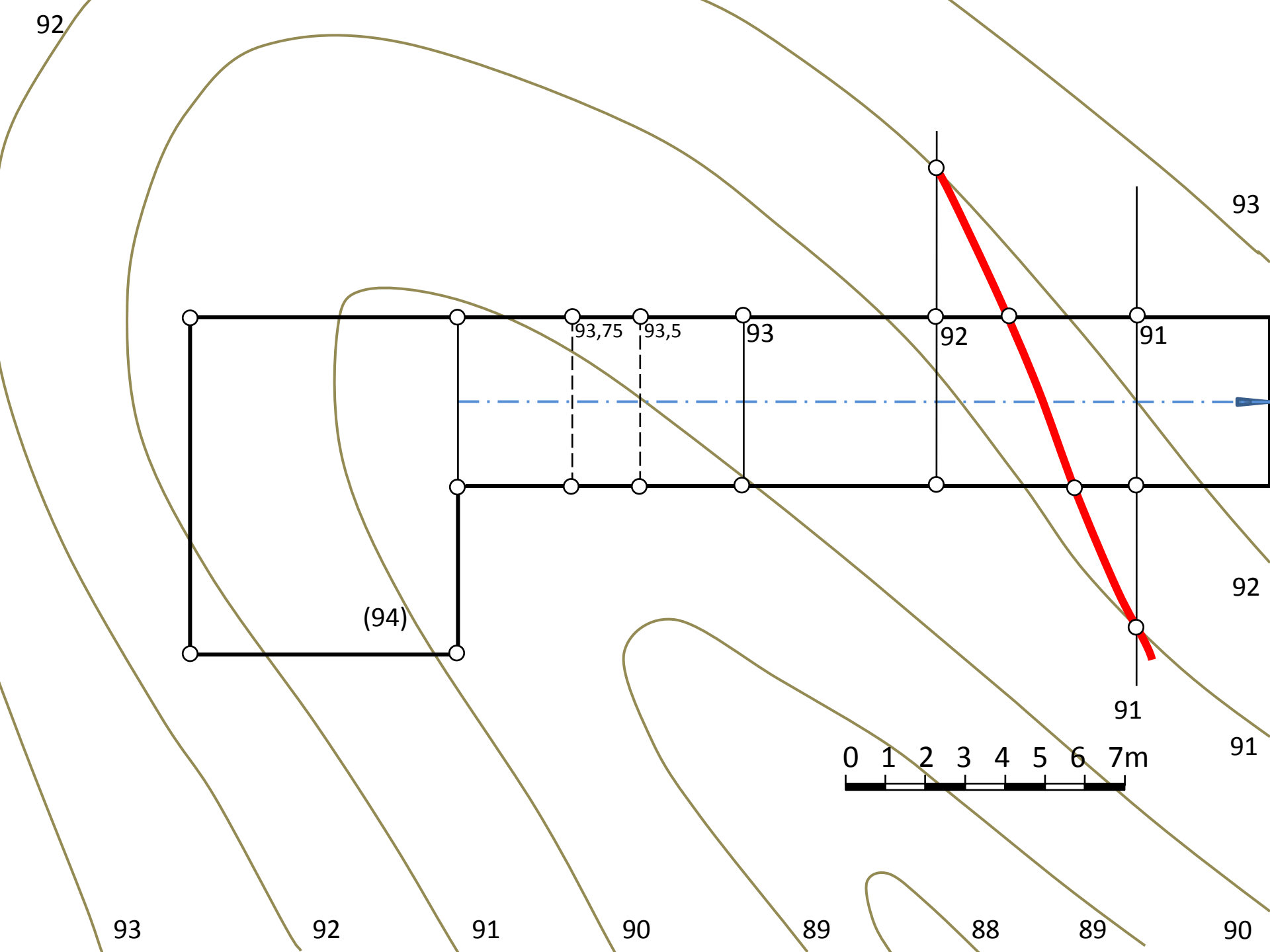



92

- nachylenie skarpy nasypu = 2/3  moduł nasypu = 1,5m
- nachylenie skarpy wykopu = 4/3  moduł wykopu = 0,75m

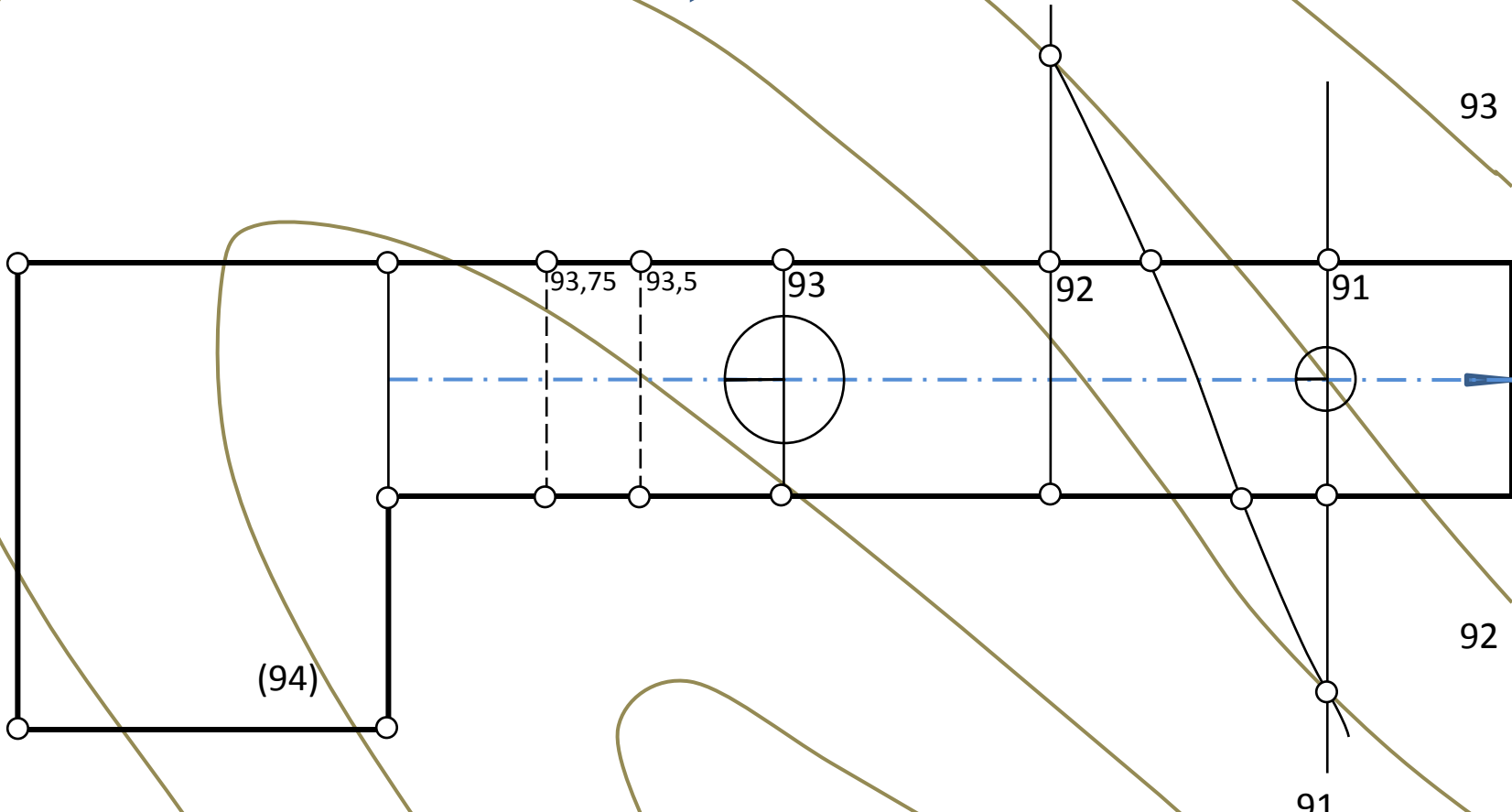

(94)

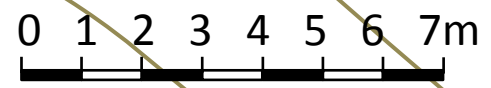

93

92

91

90



89

88

89

90

92

- nachylenie skarpy nasypu = 2/3  moduł nasypu = 1,5m
- nachylenie skarpy wykopu = 4/3  moduł wykopu = 0,75m

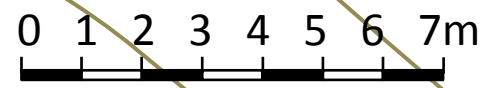
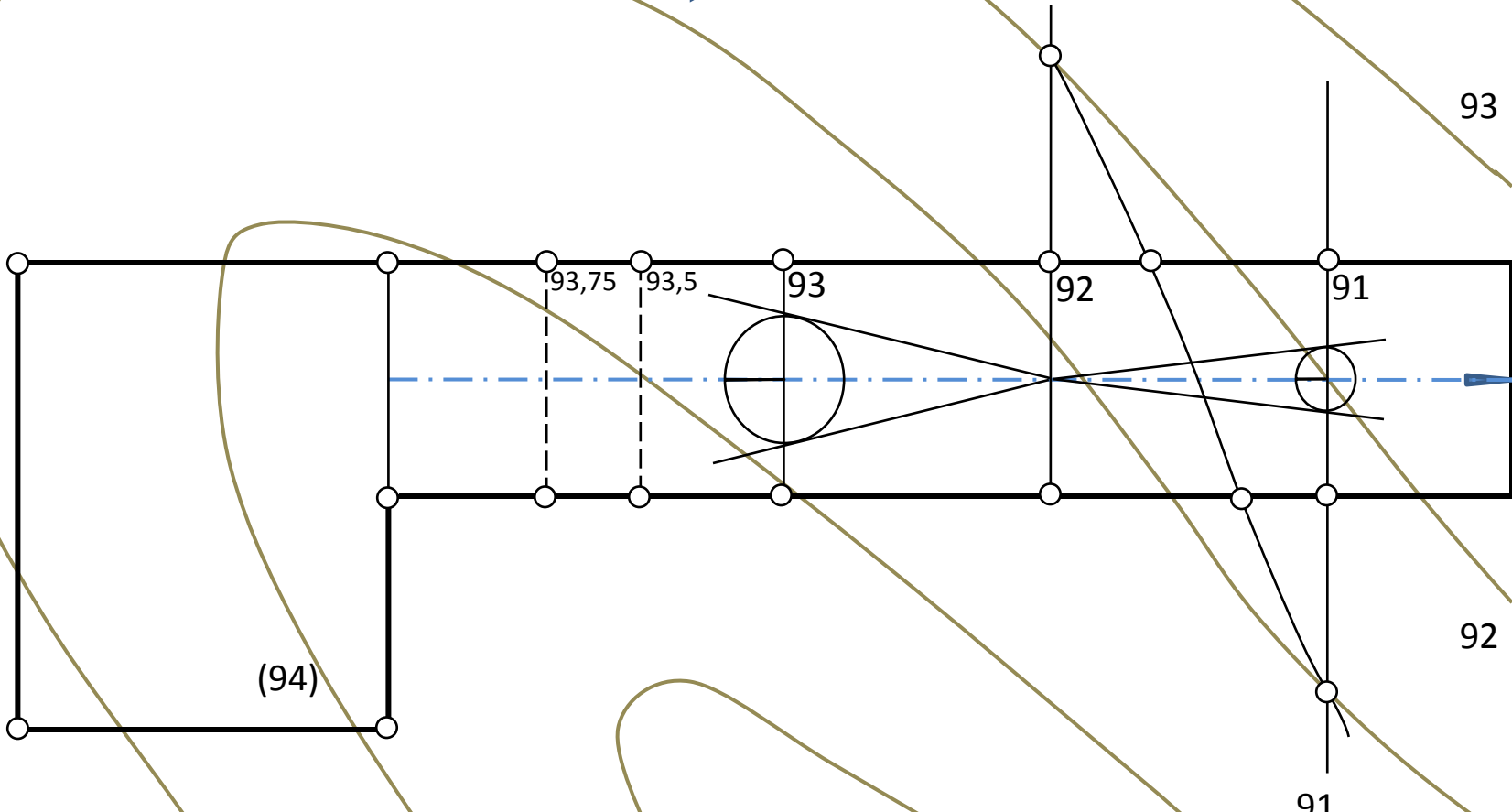

93

92

91

90

89

88

89

90

93

92

91

92

- nachylenie skarpy nasypu = 2/3 → moduł nasypu = 1,5m
- nachylenie skarpy wykopu = 4/3 → moduł wykopu = 0,75m

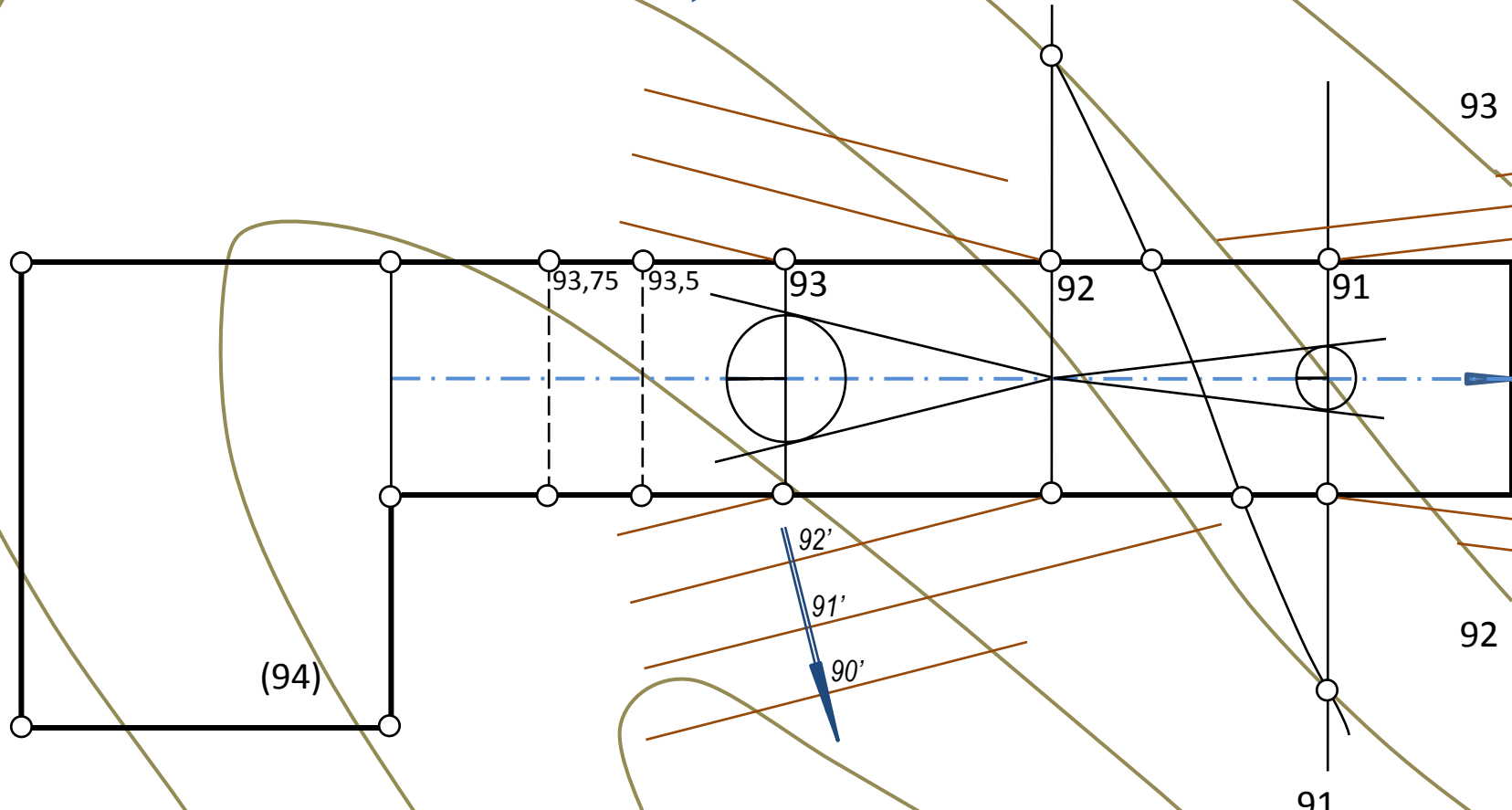

(94)

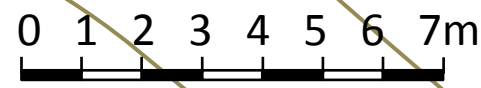

93

92

91

90

89

88

89

90

93

92

91

91

92

93

92'

91'

90'



93,75

93,5

91

90

92

- nachylenie skarpy nasypu = 2/3  moduł nasypu = 1,5m
- nachylenie skarpy wykopu = 4/3  moduł wykopu = 0,75m

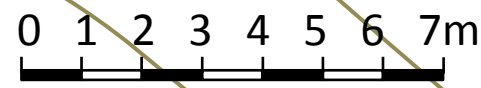
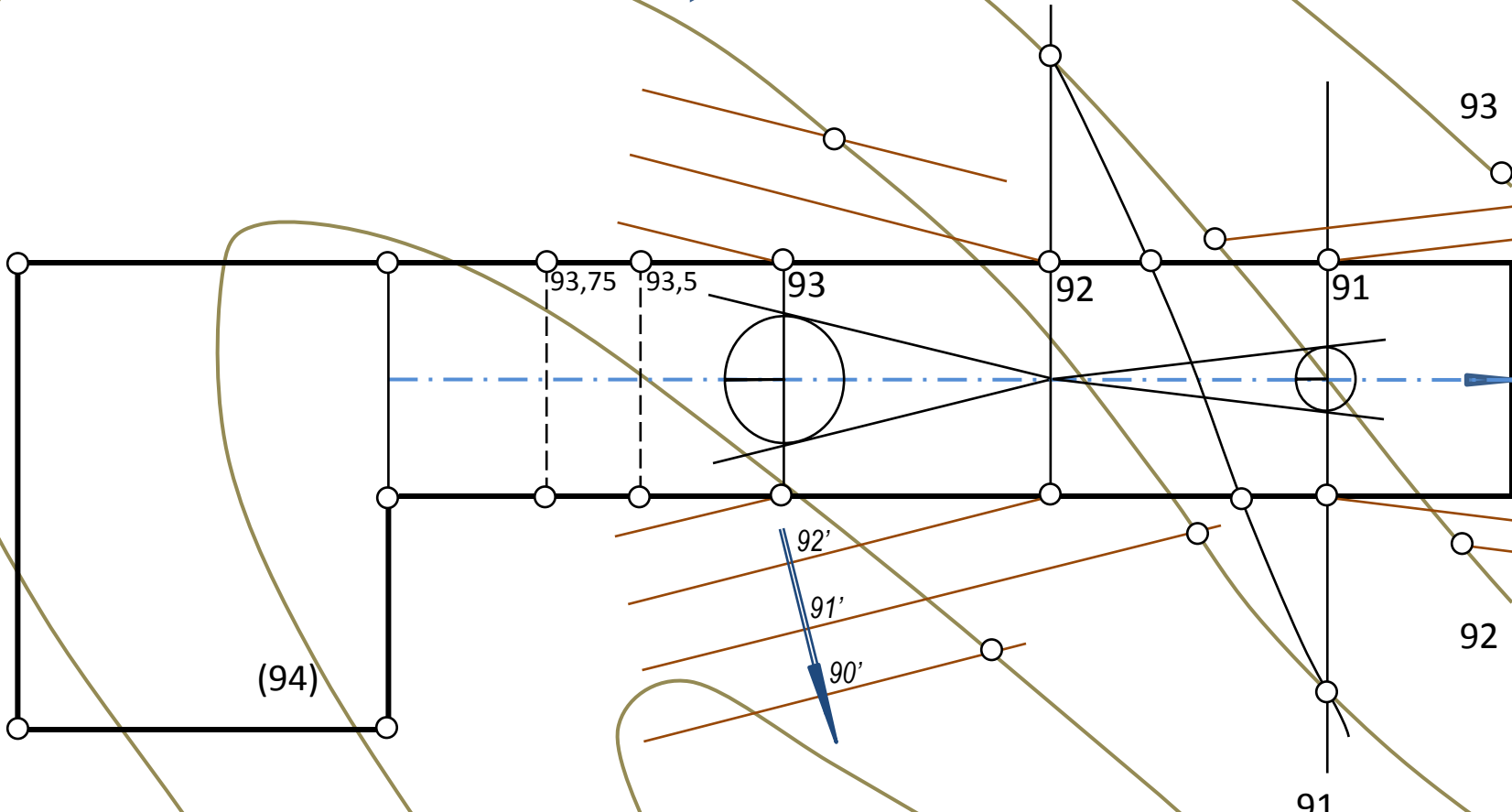

93

92

91

90

89

88

89

90

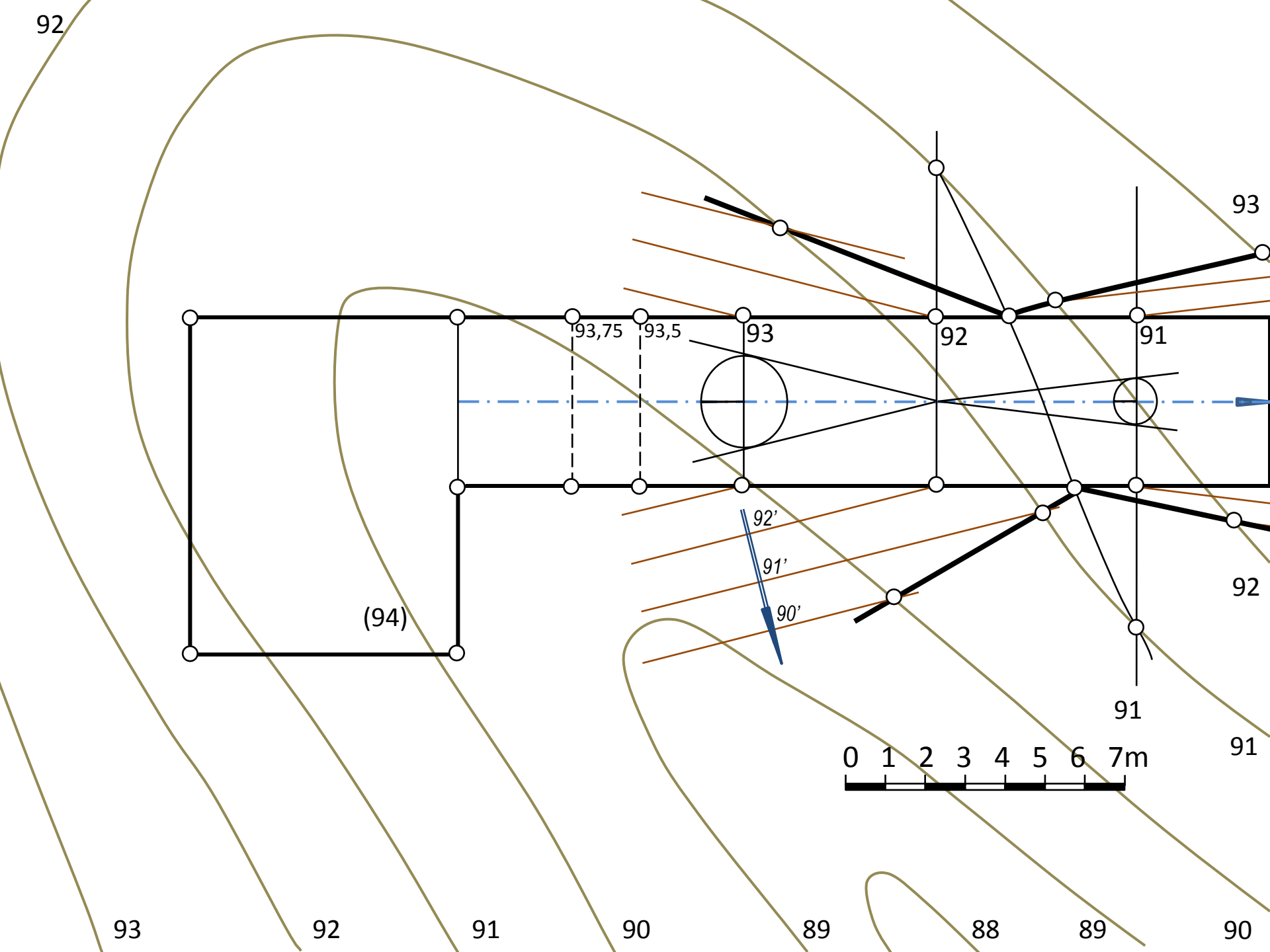

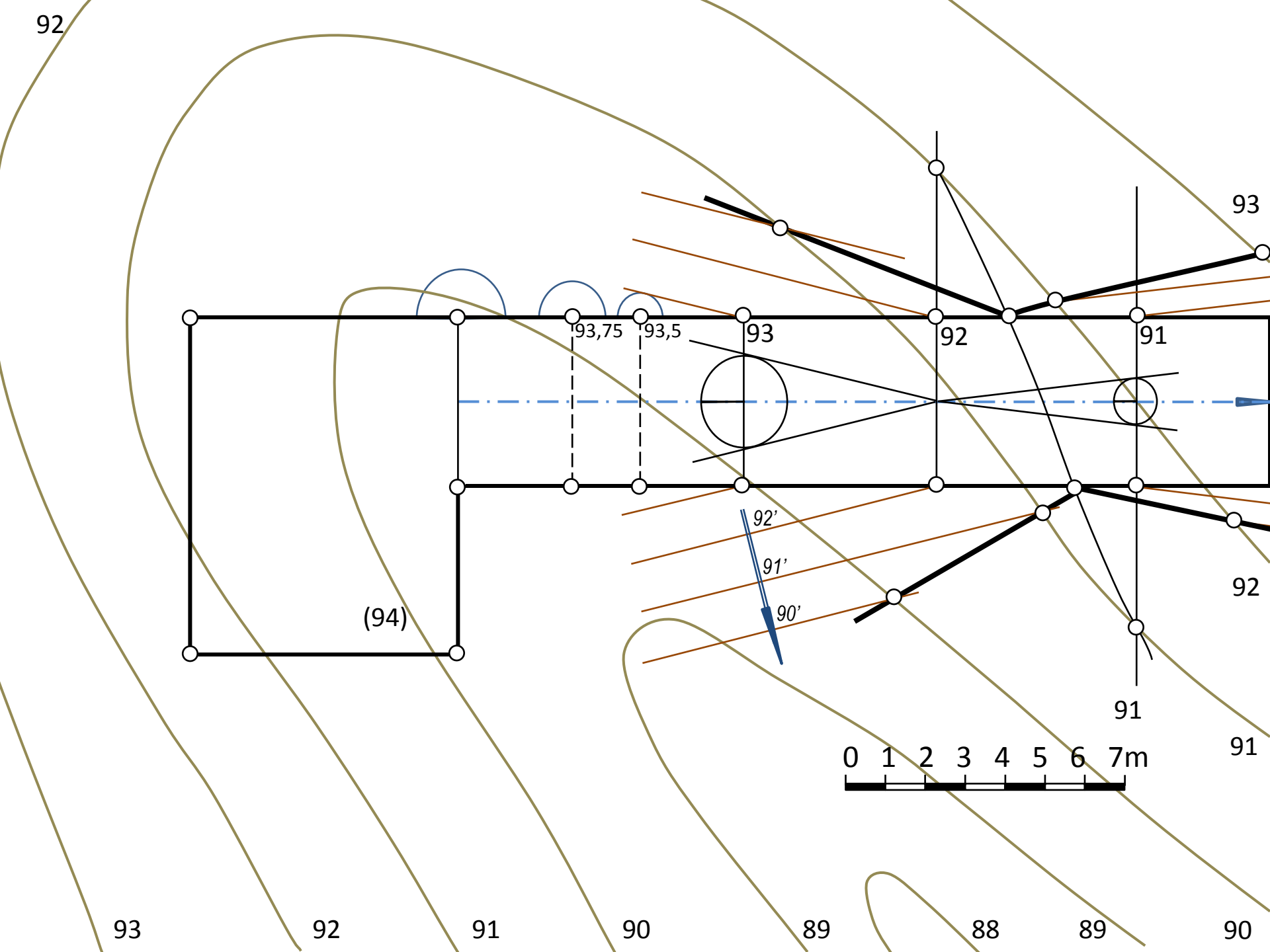

92

93

(94)

93,75

93,5

93

92

91

92'

91'

90'

92

91

91

0 1 2 3 4 5 6 7m

93

92

91

90

89

88

89

90

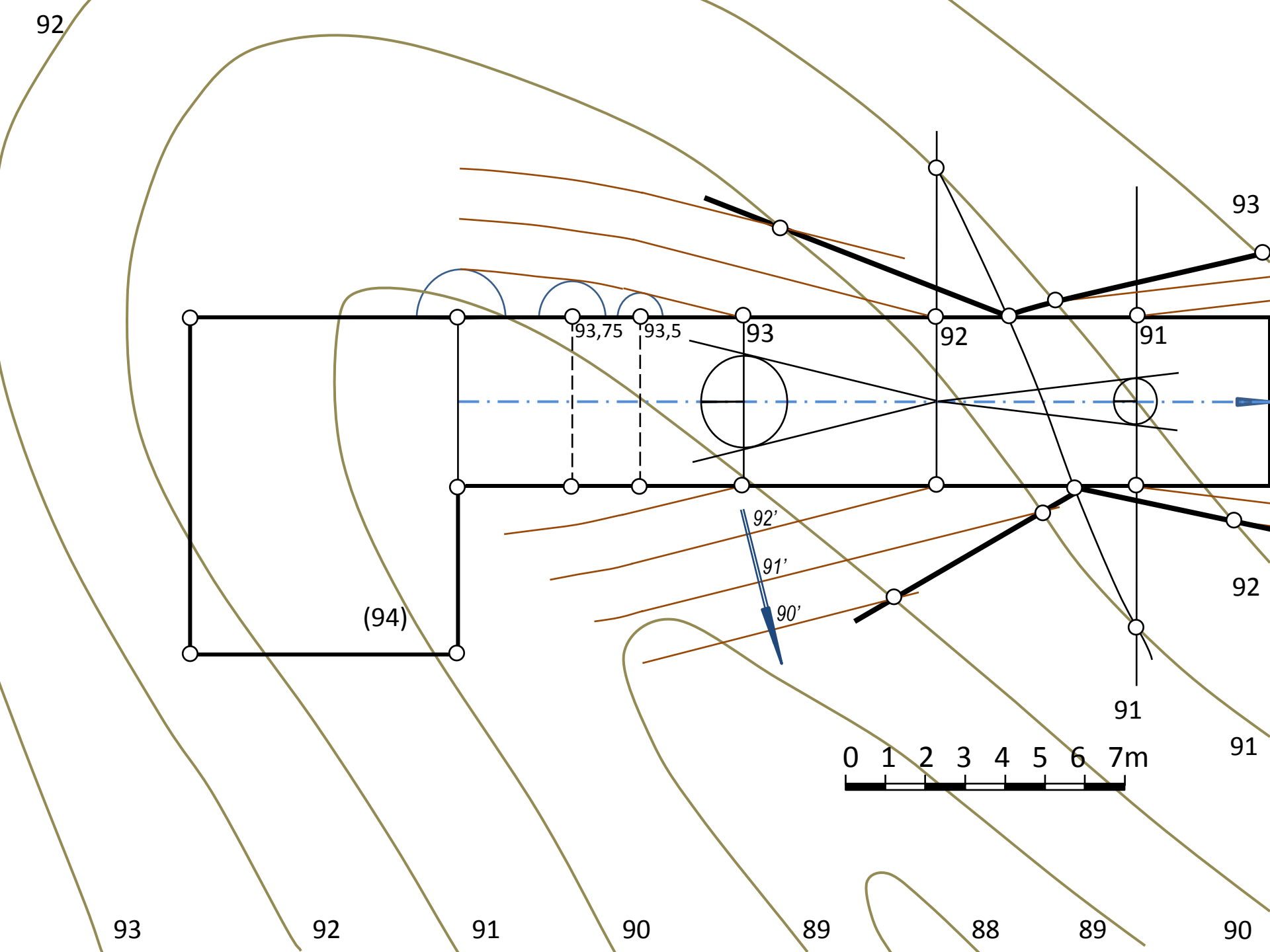

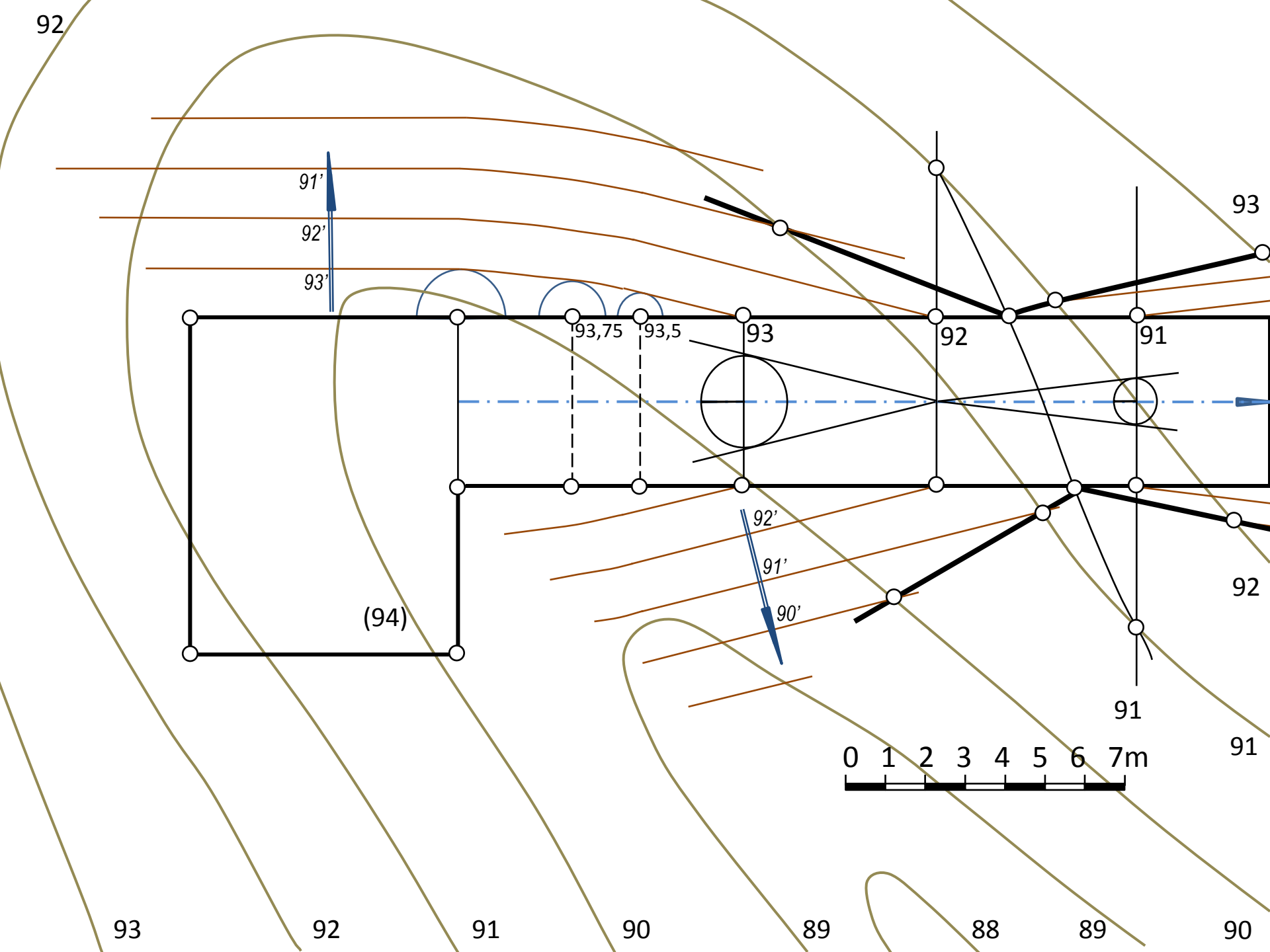

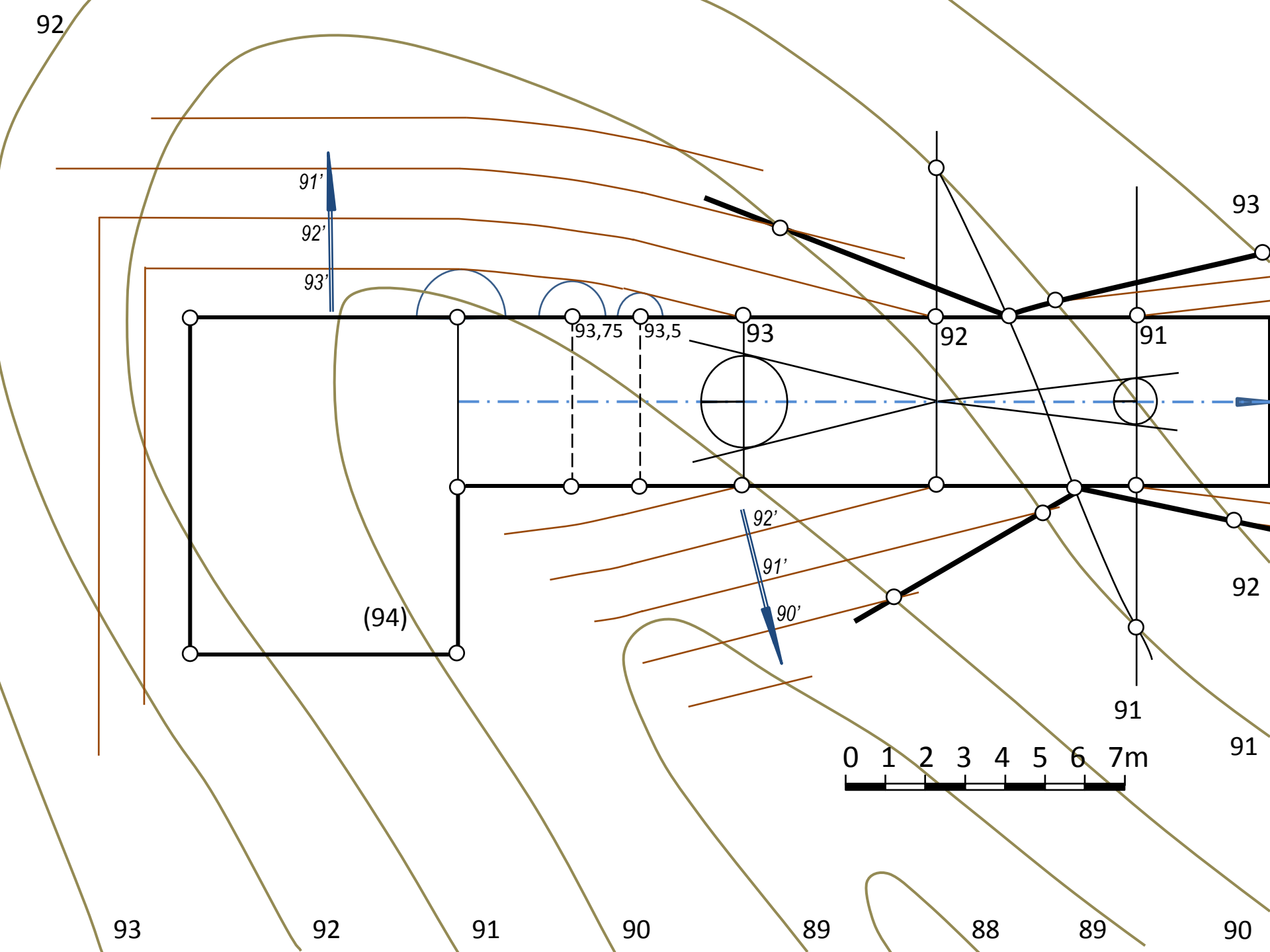

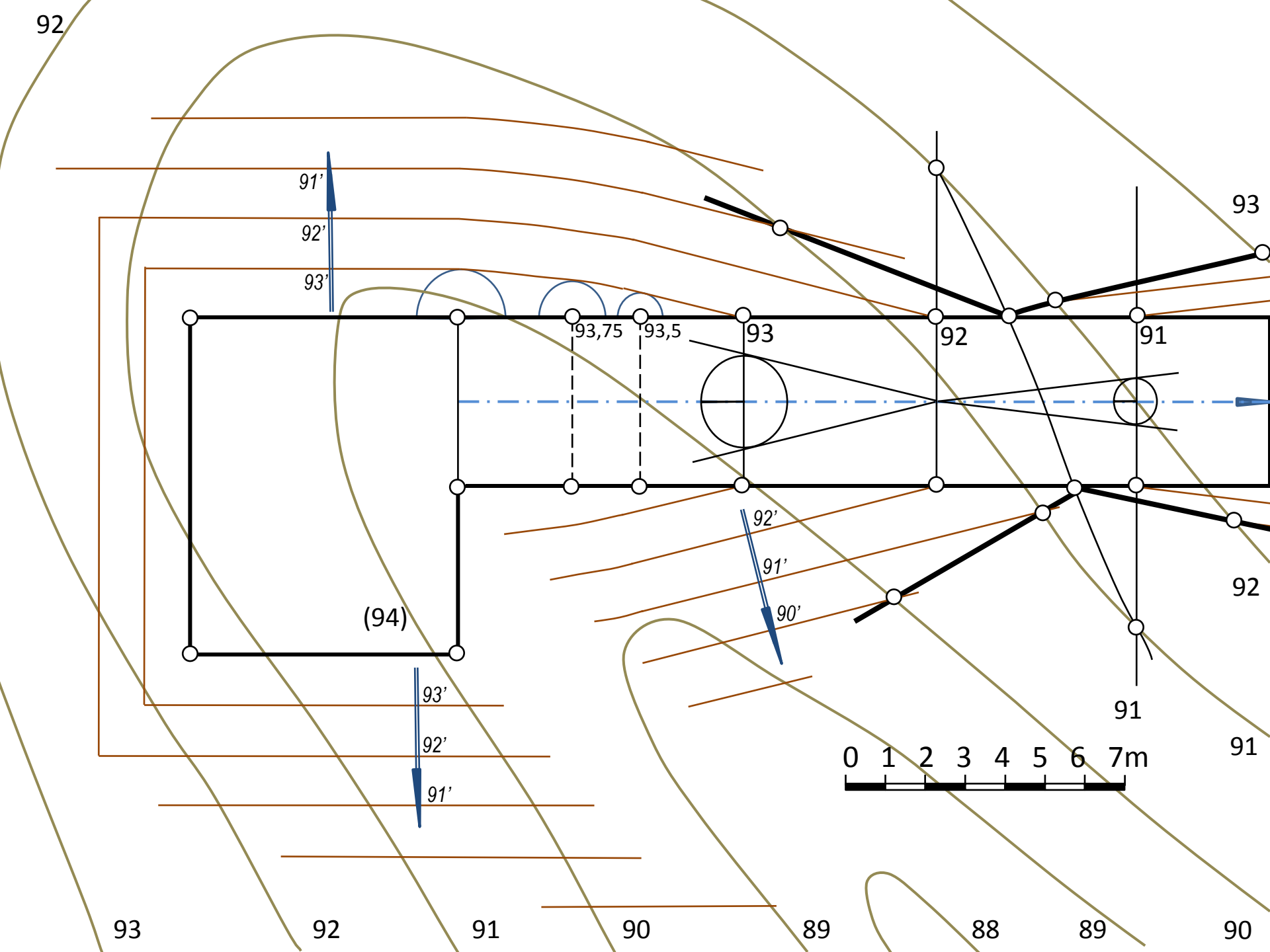

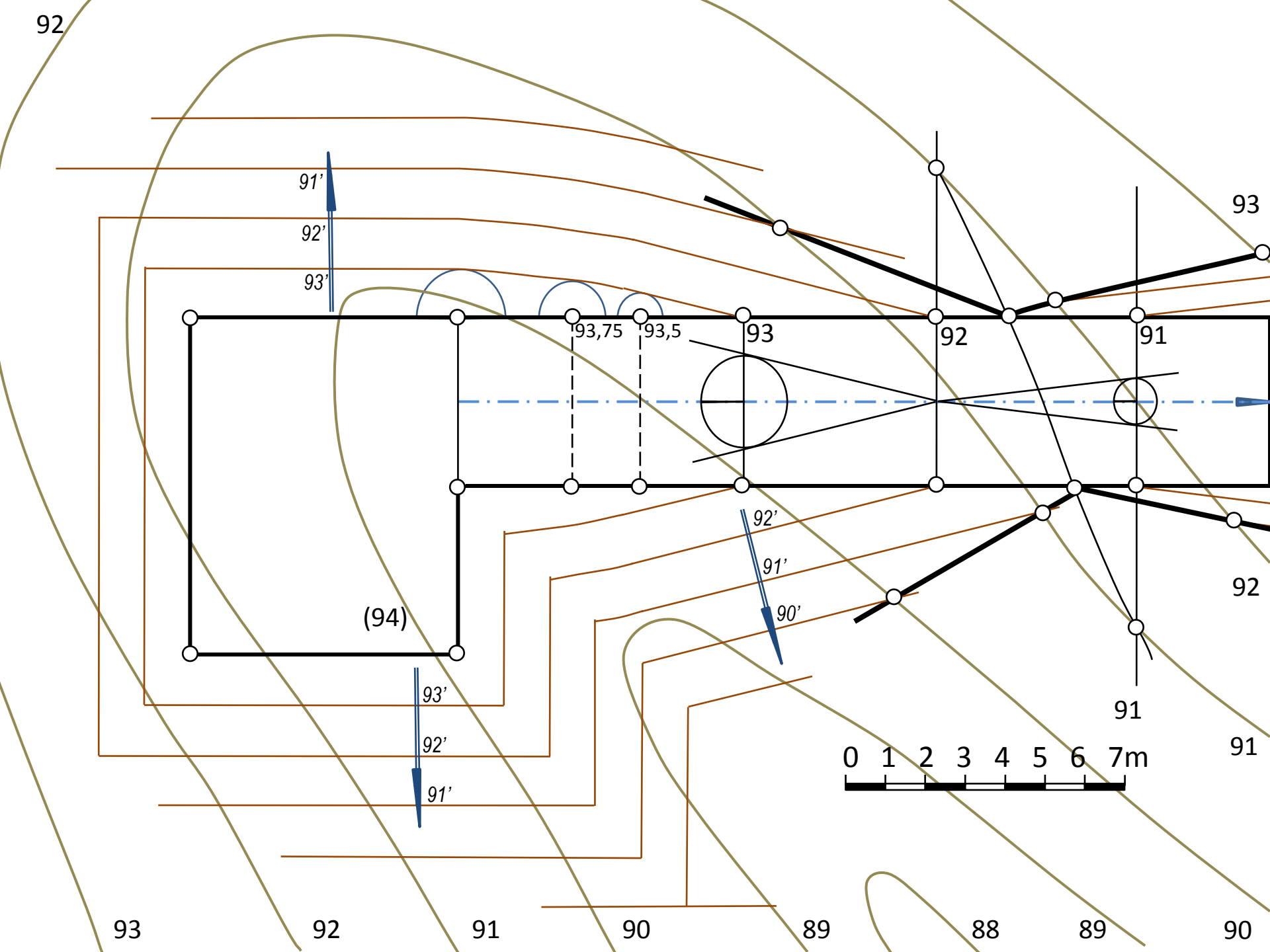

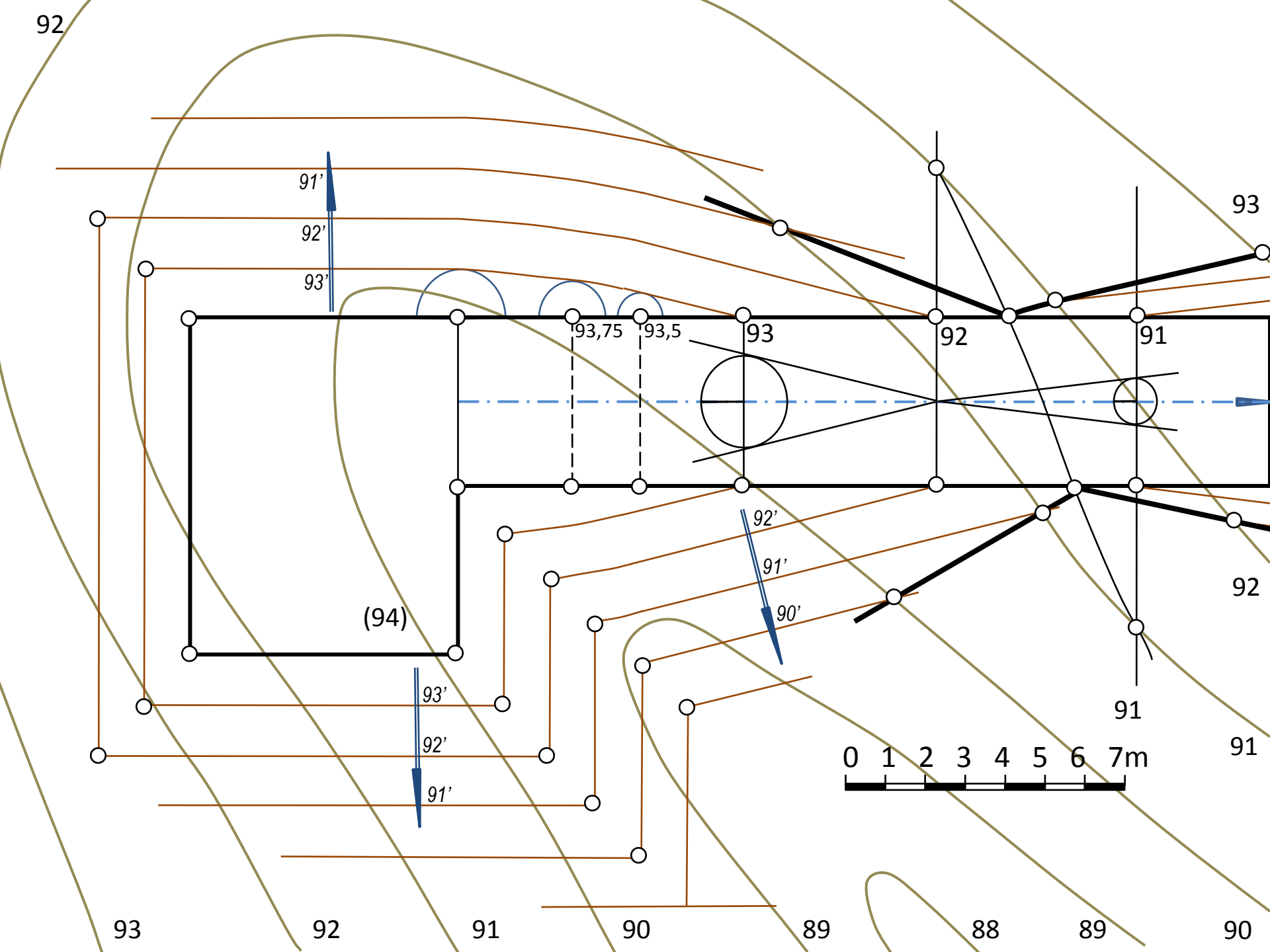

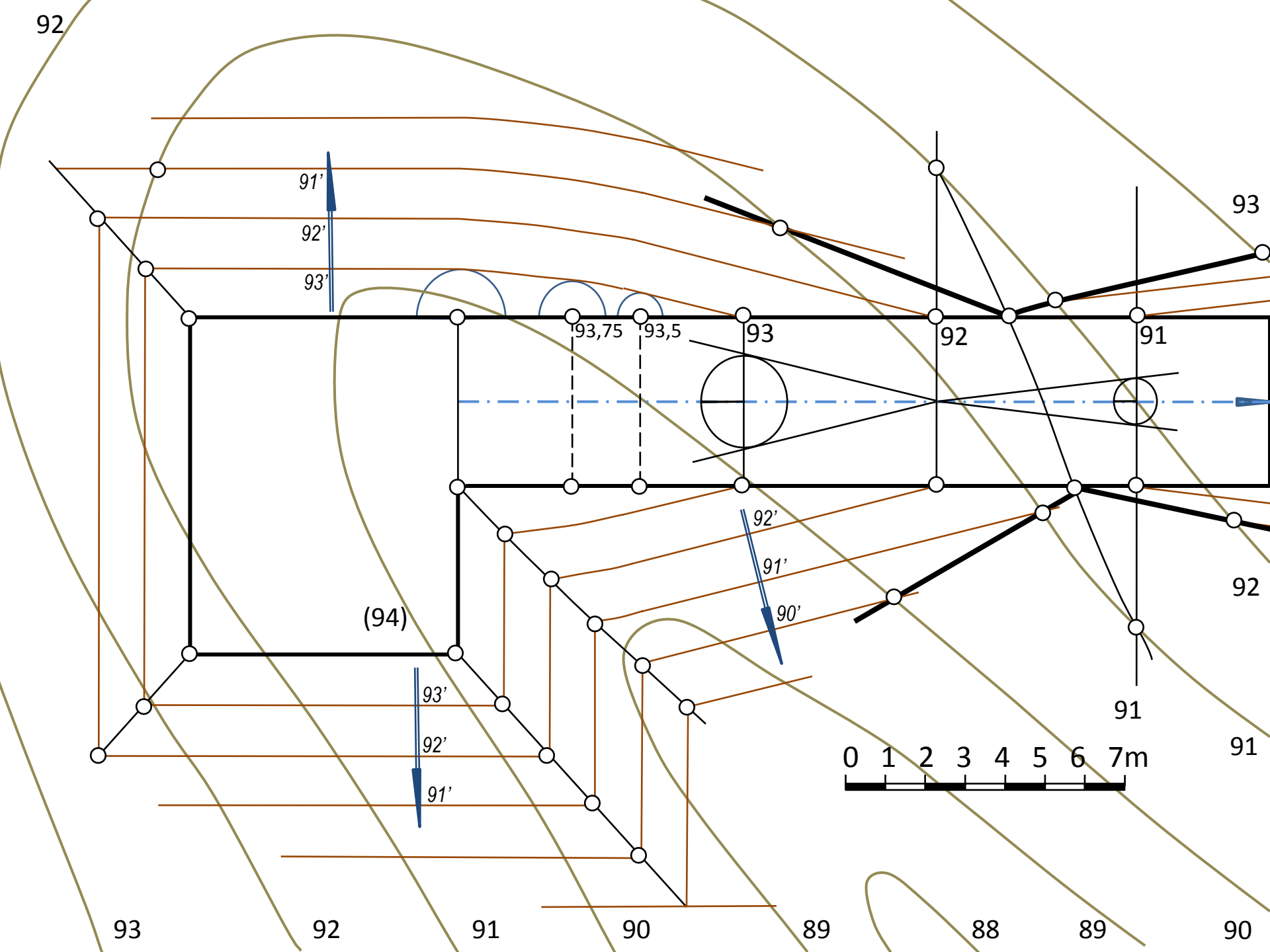

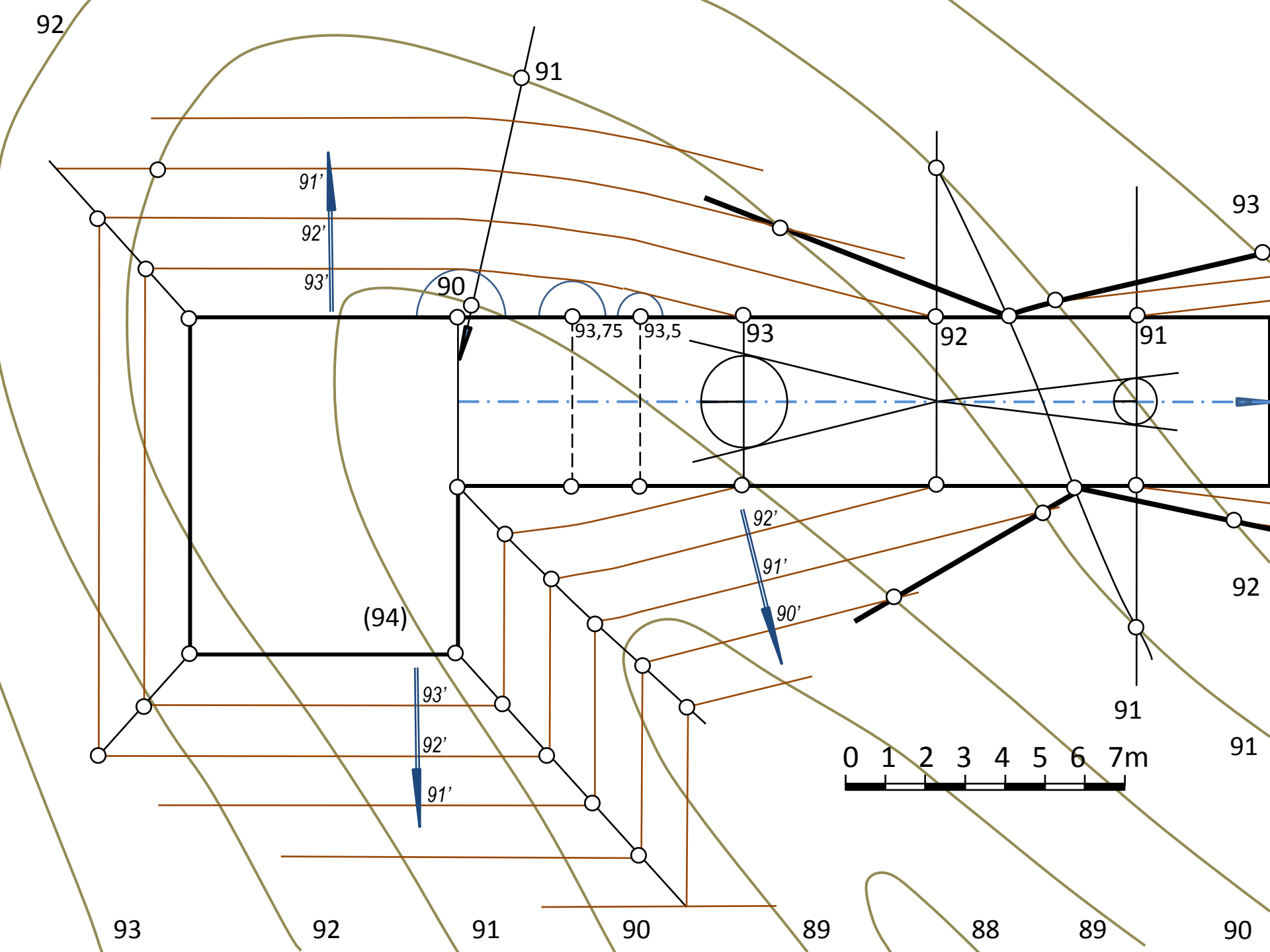

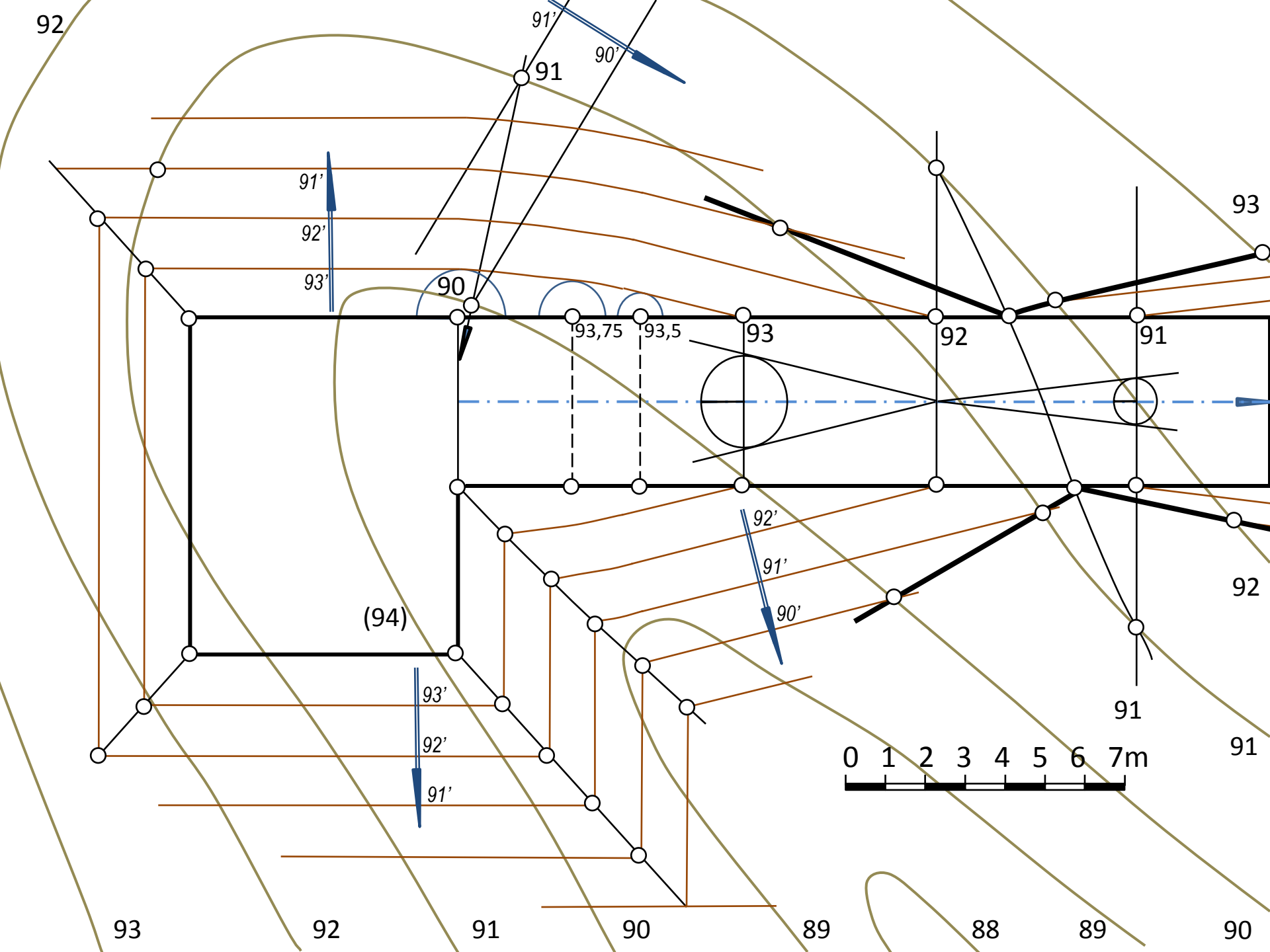

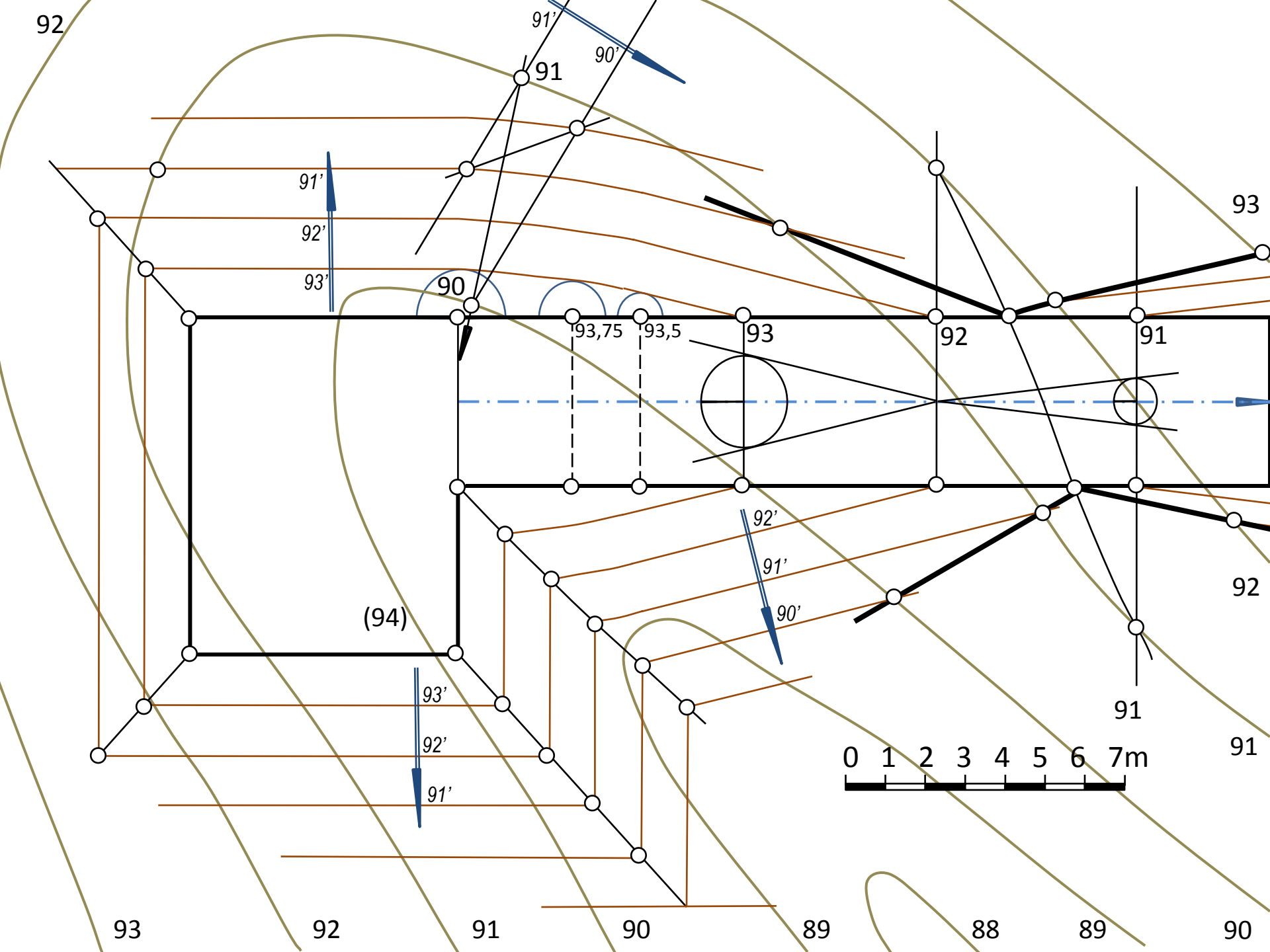

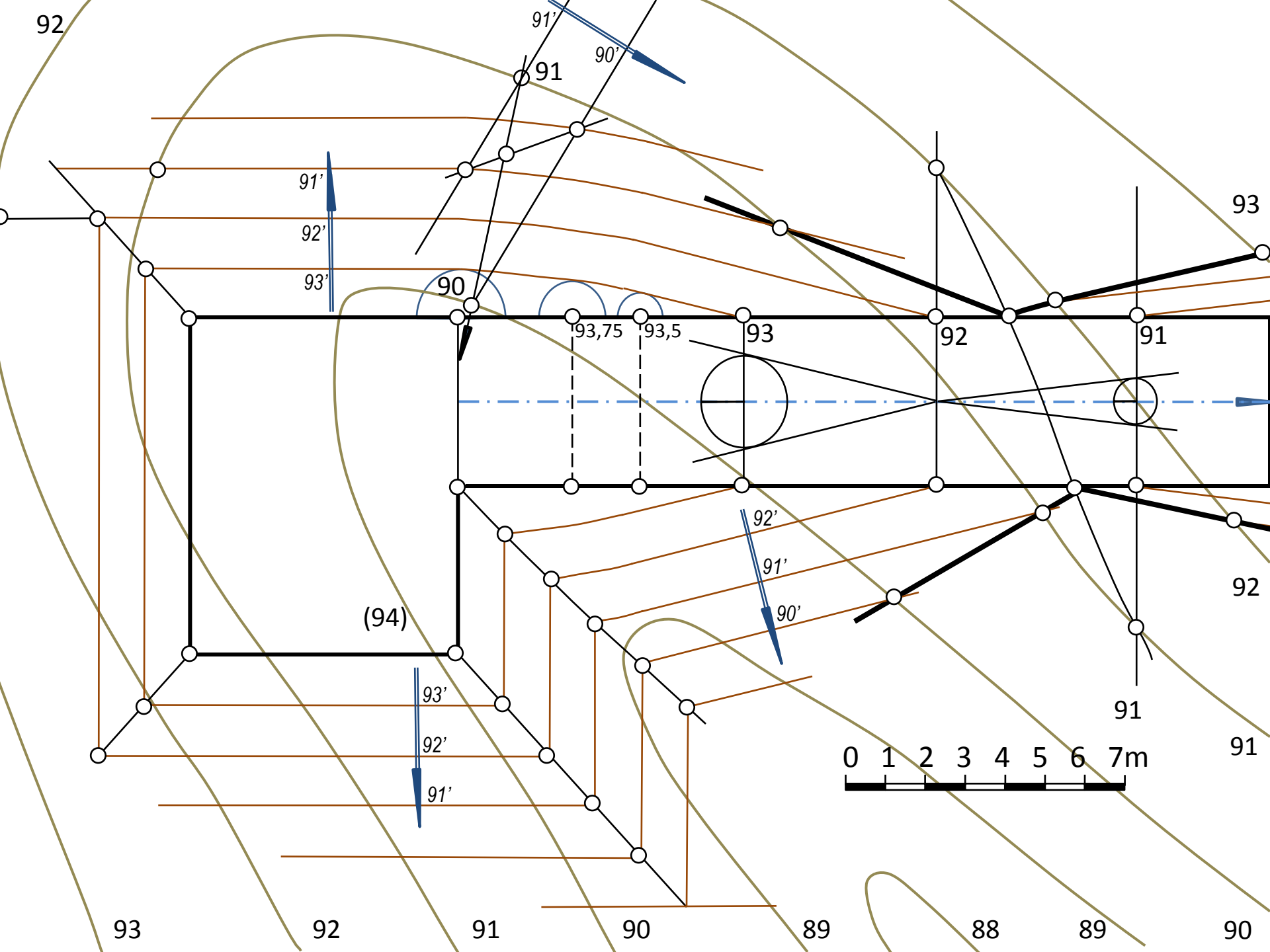

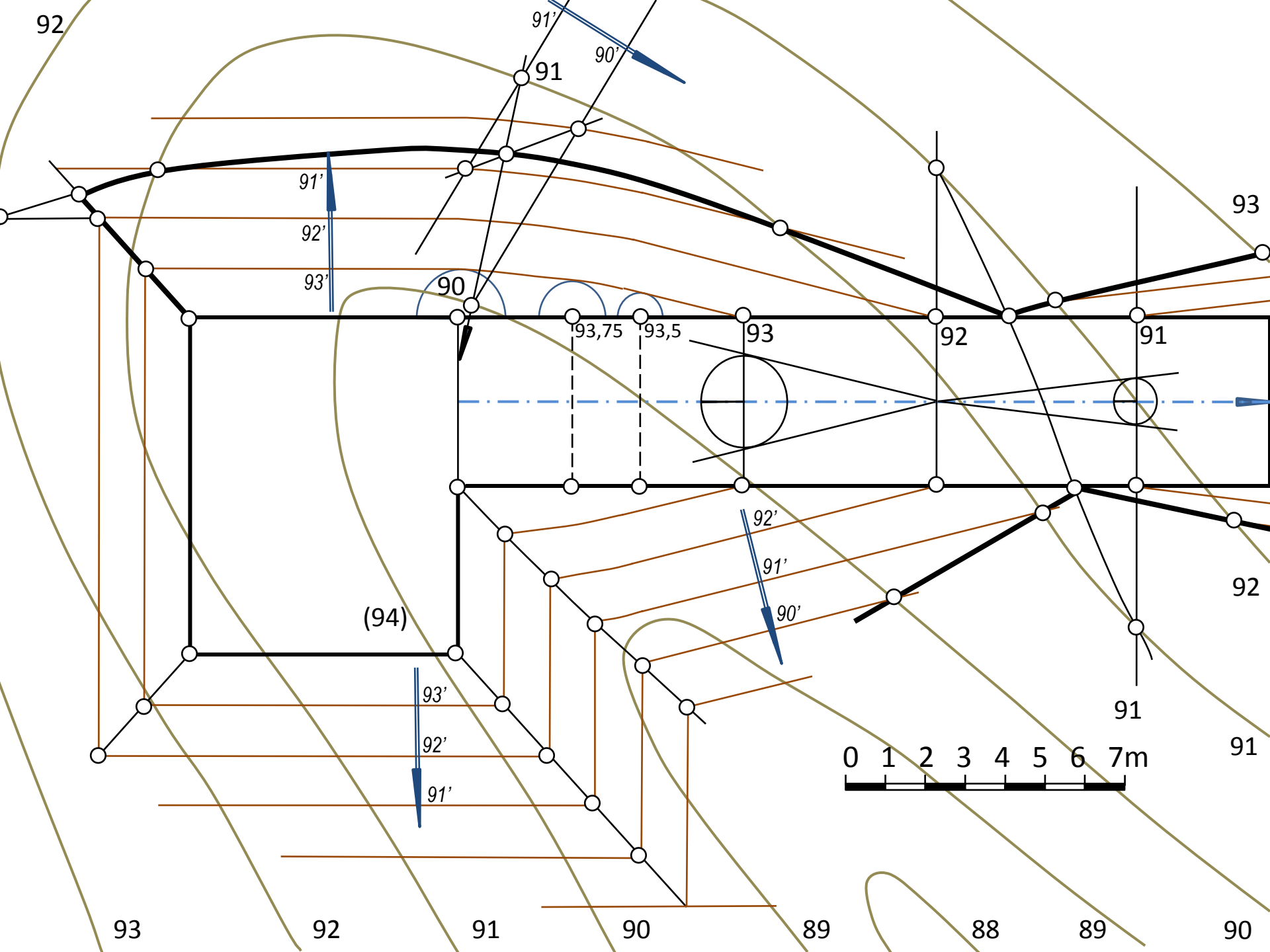

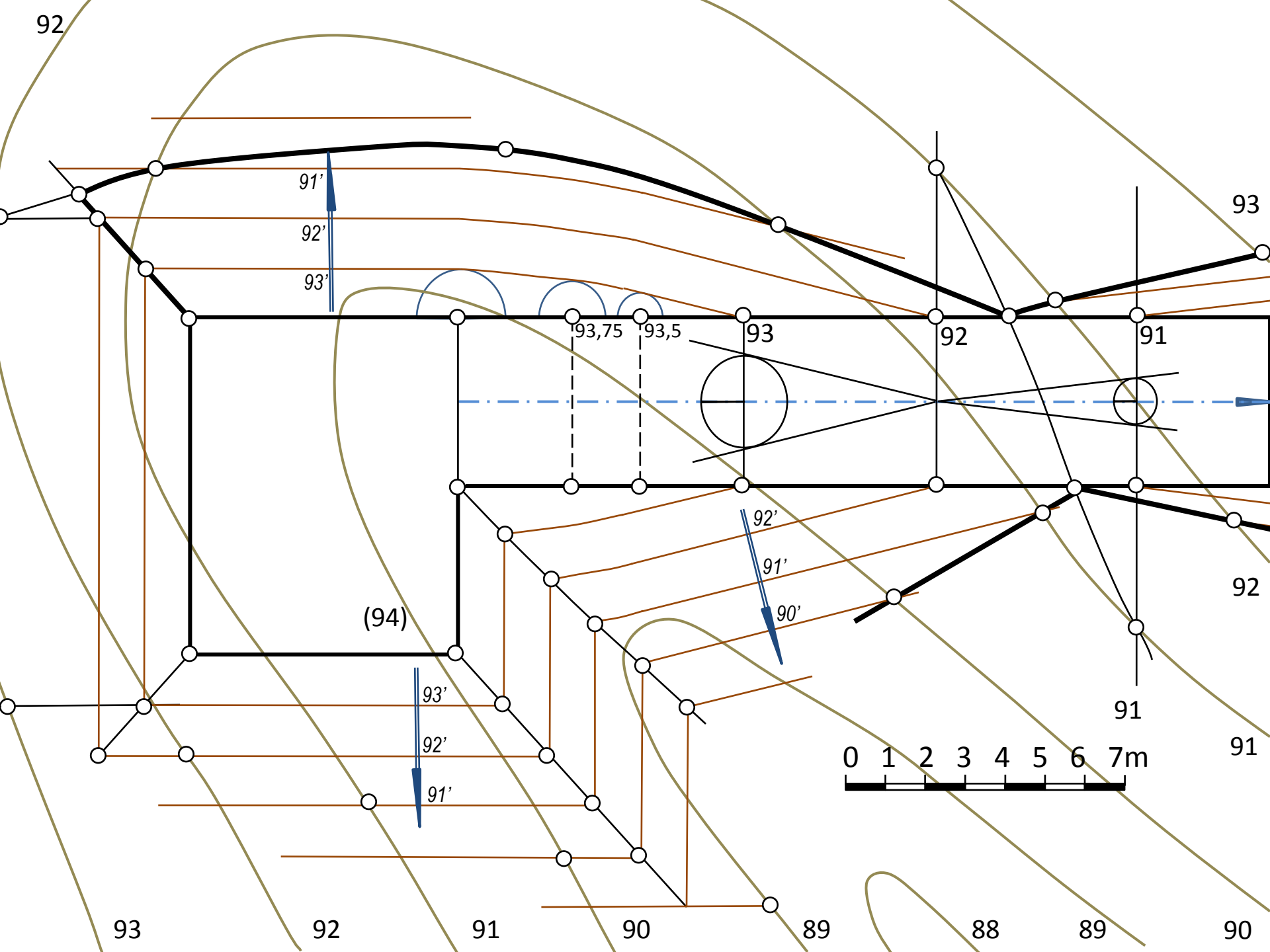

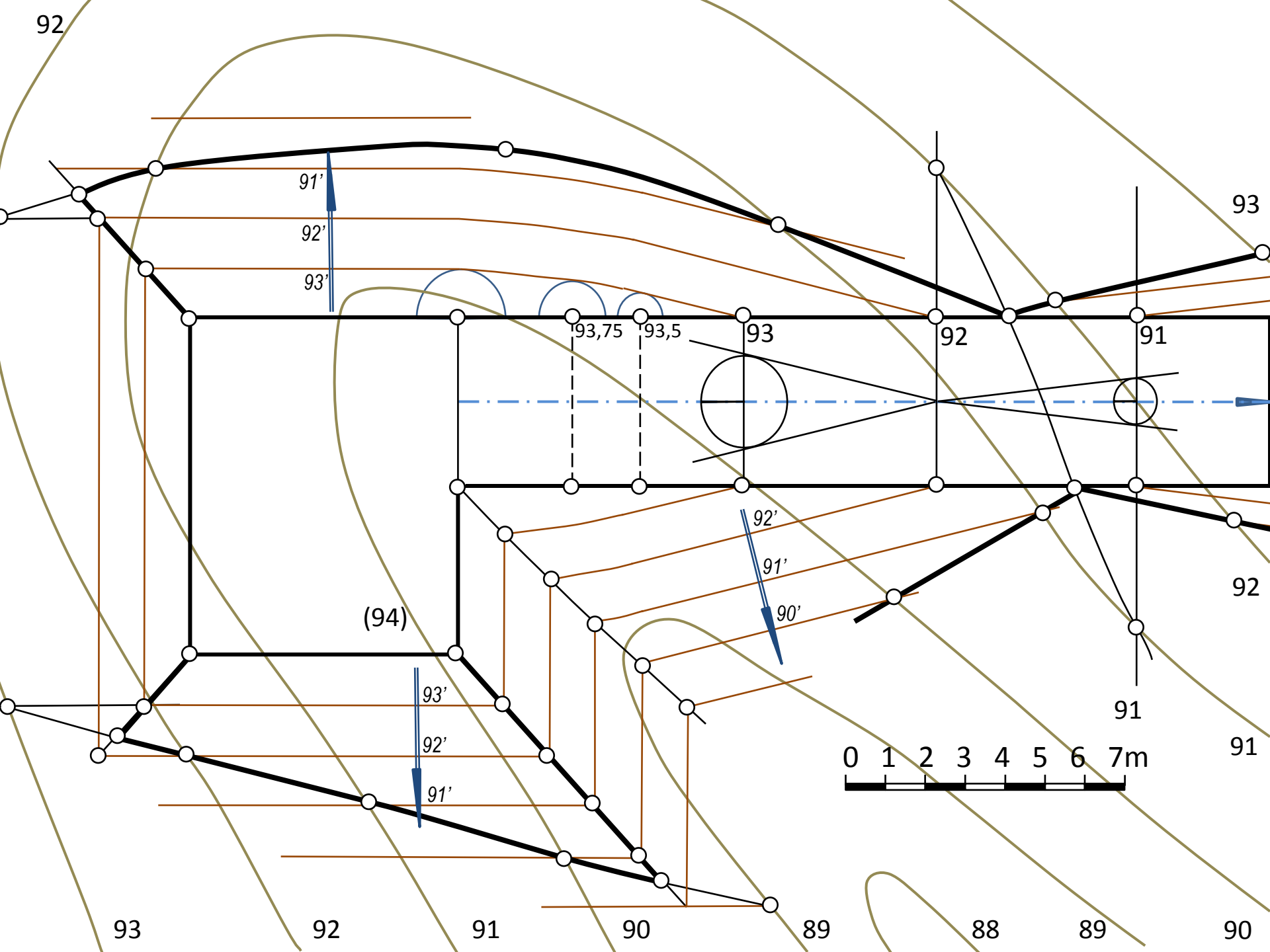

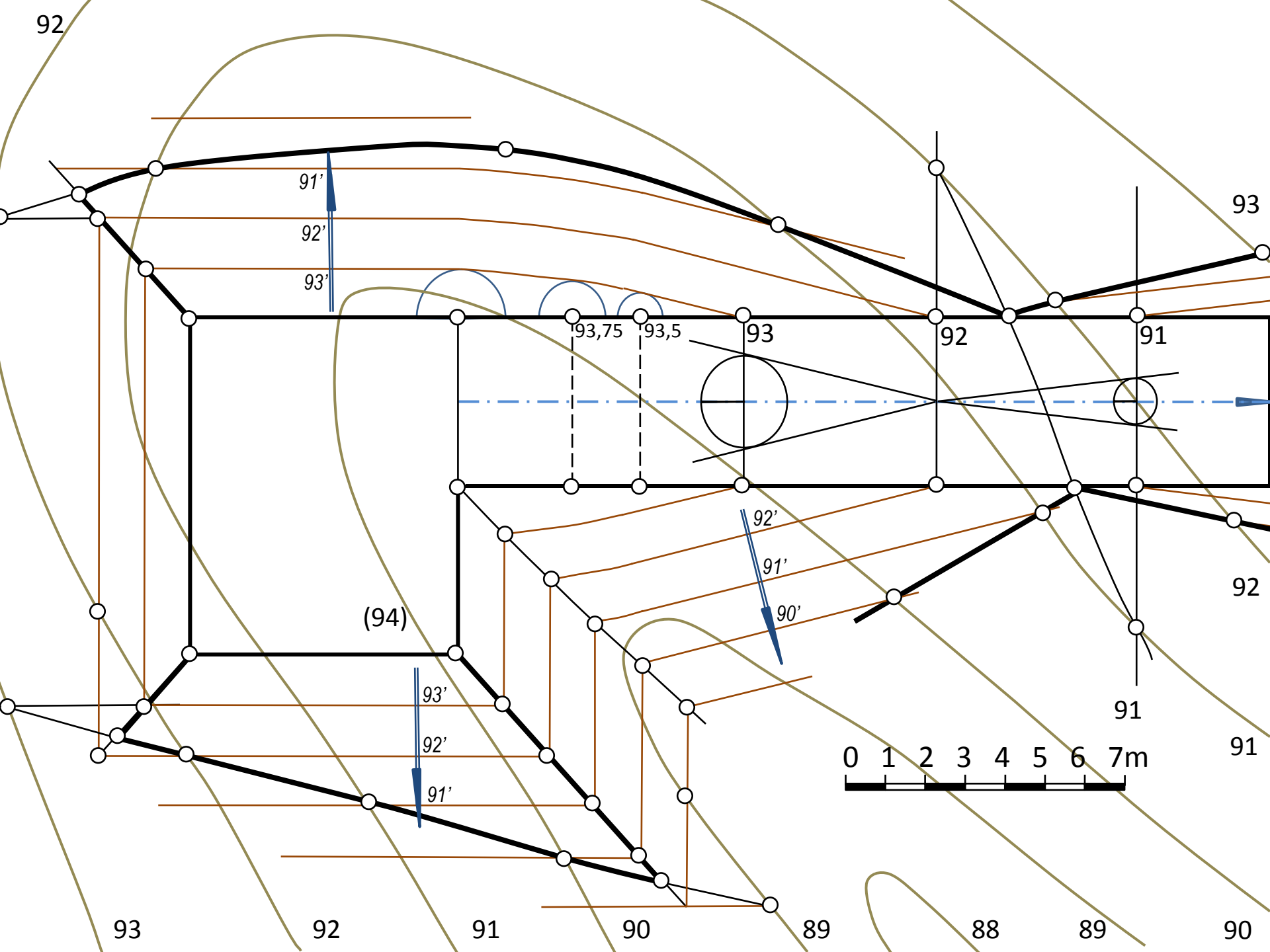

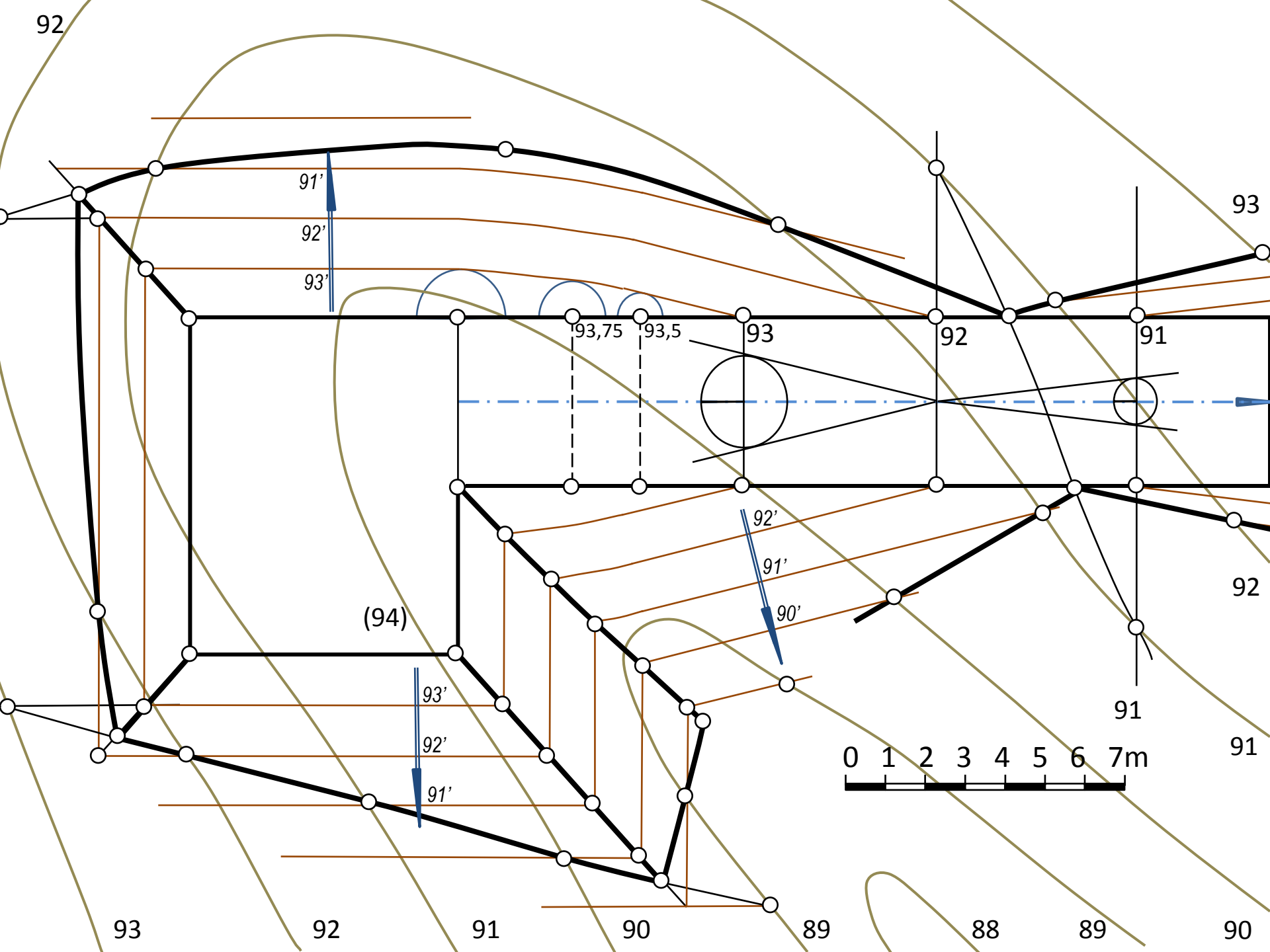

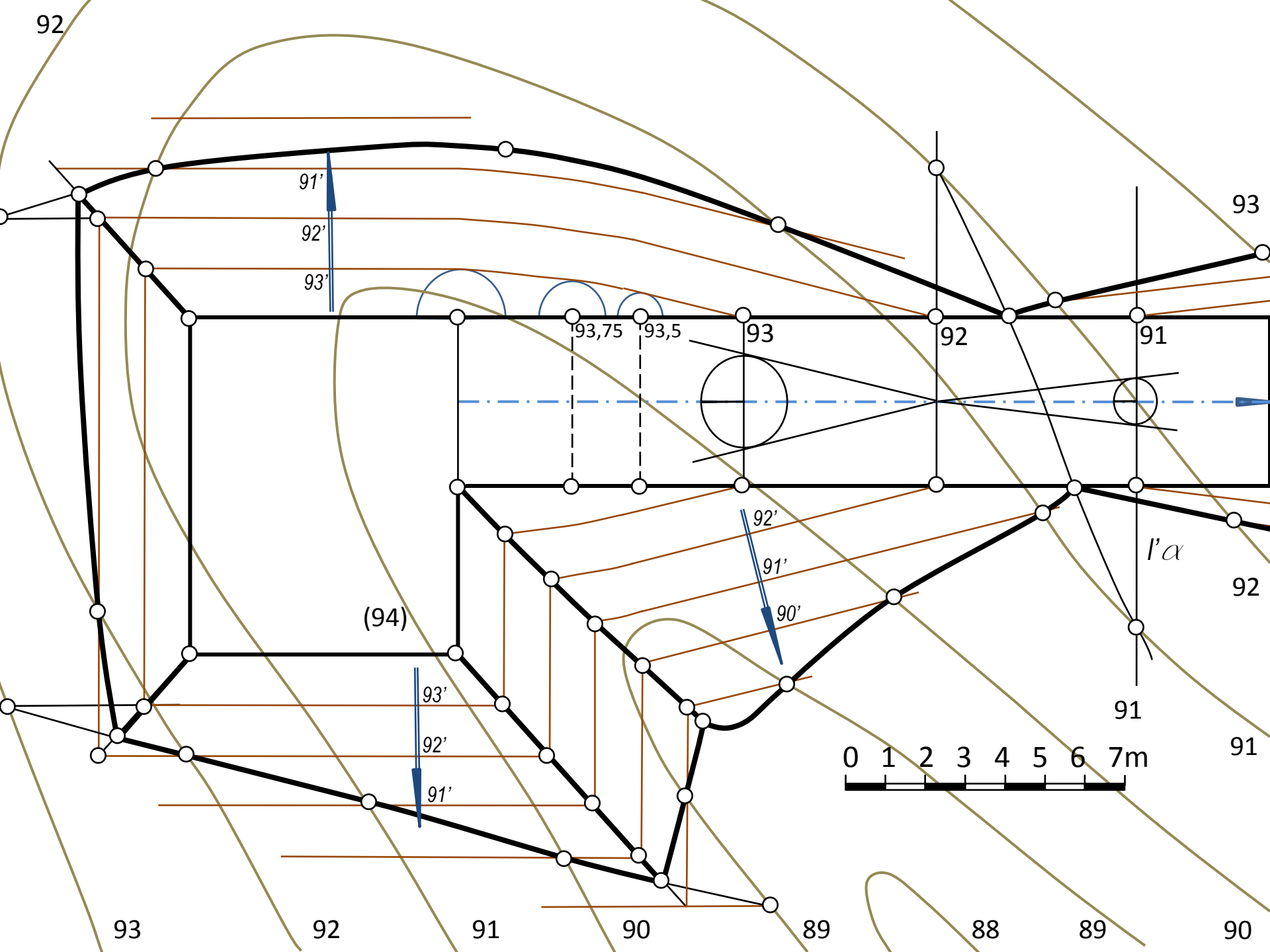

Połączenie odcinków dróg o przeciwnym spadku

- nachylenie drogi = 15%
- nachylenie skarpy nasypu = 4/5
- nachylenie skarpy wykopu = 4/3
- promień krzywizny pionowej = 35m

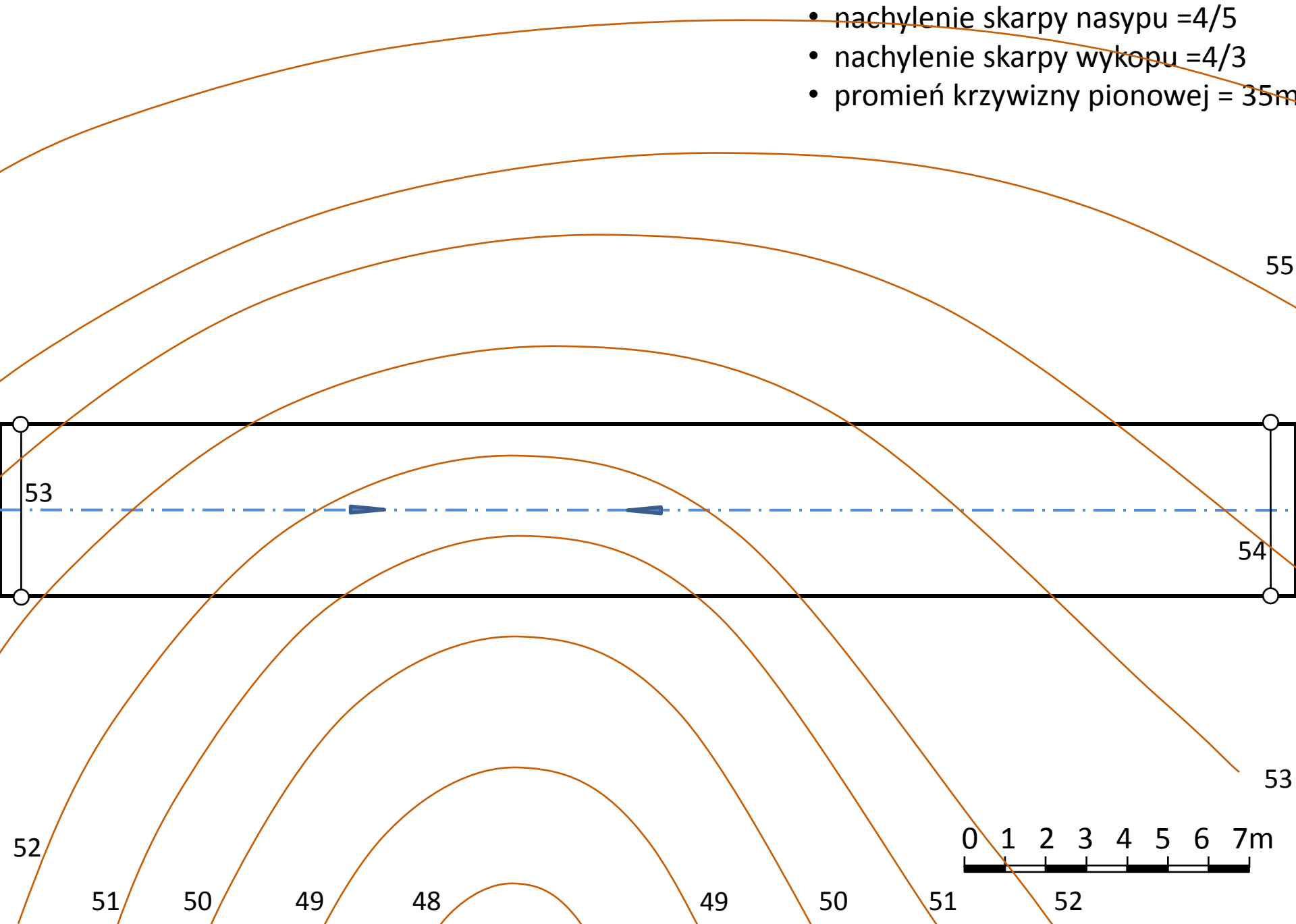

Połączenie odcinków dróg o przeciwnym spadku

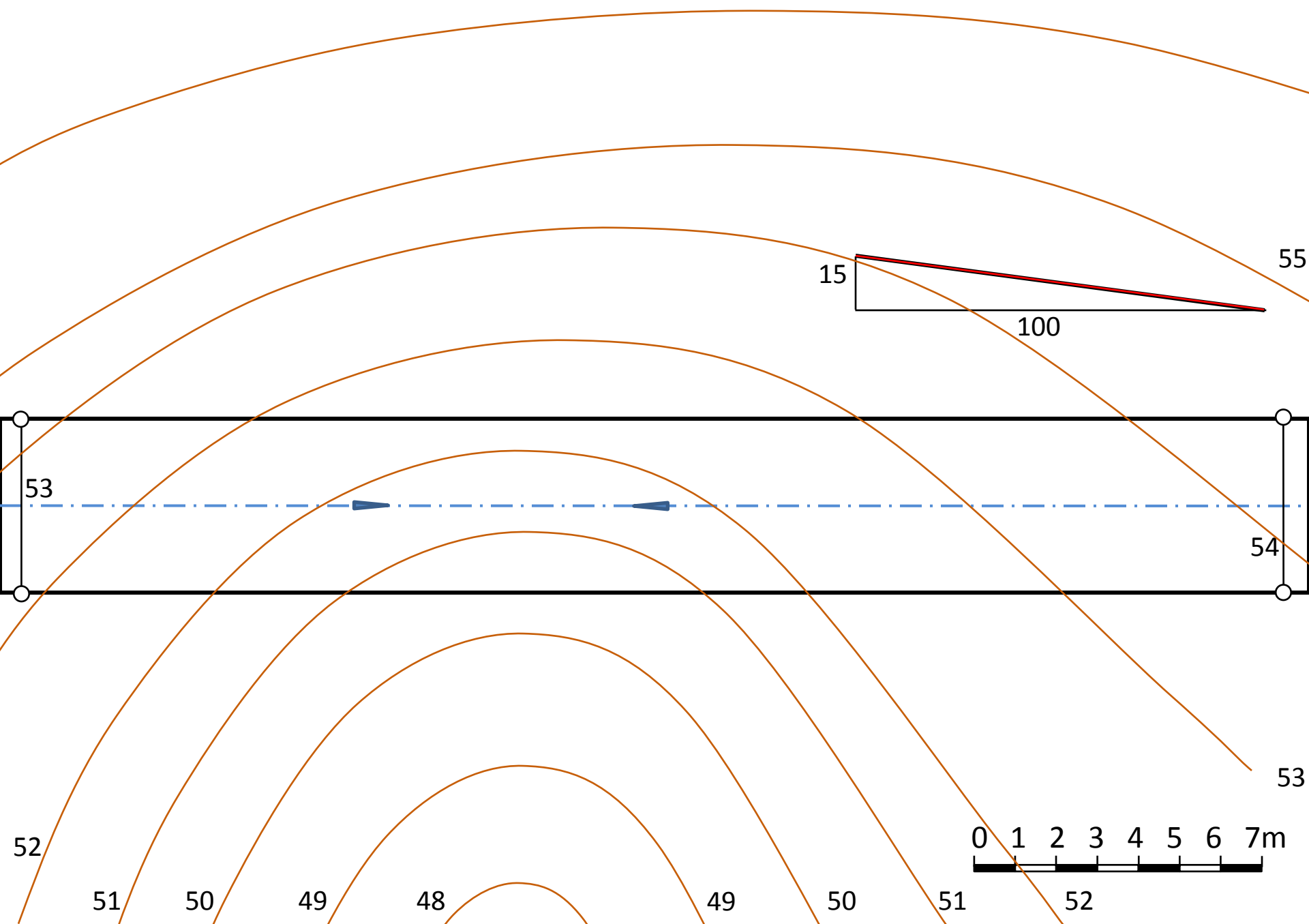

Połączenie odcinków dróg o przeciwnym spadku

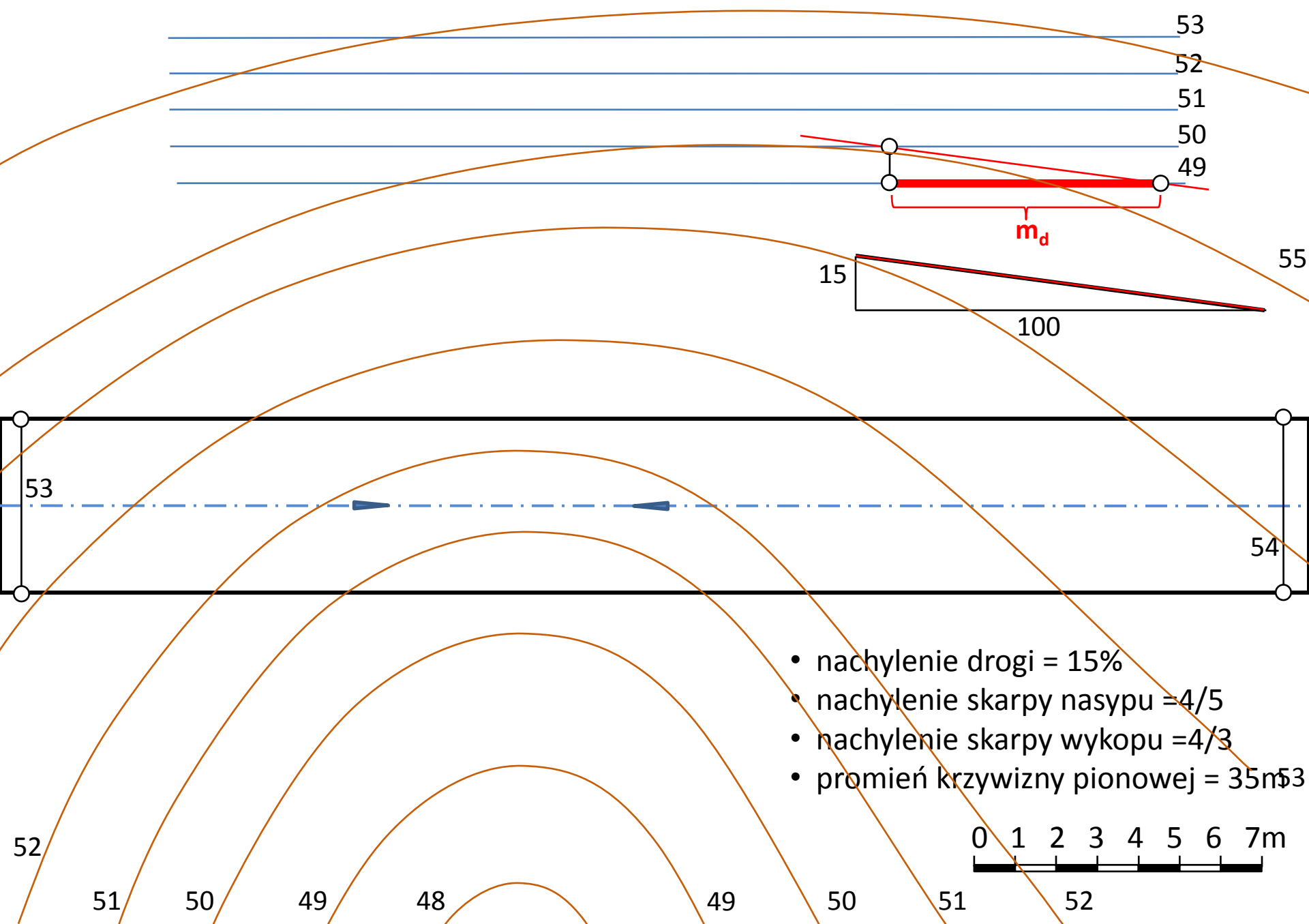

Połączenie odcinków dróg o przeciwnym spadku

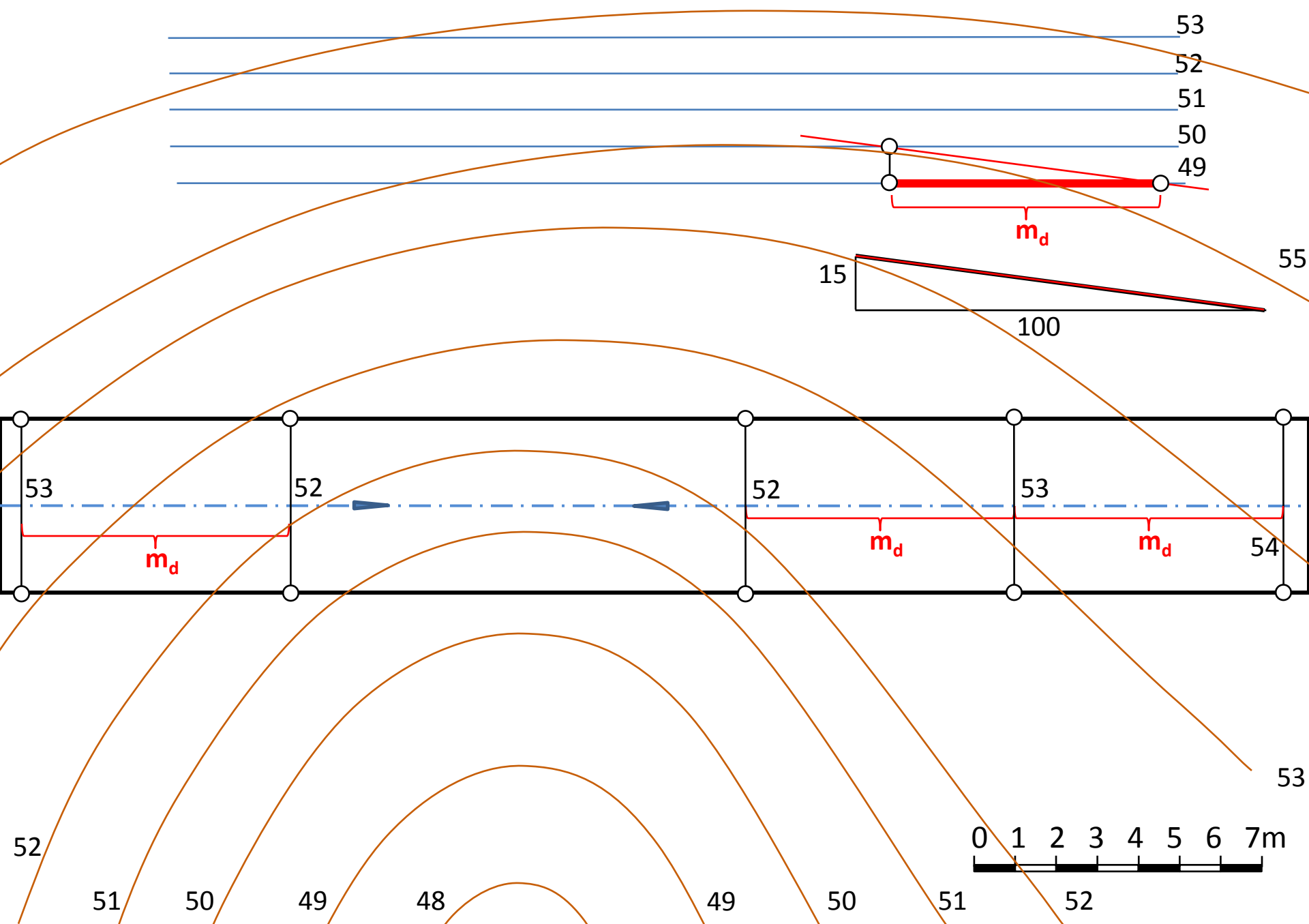

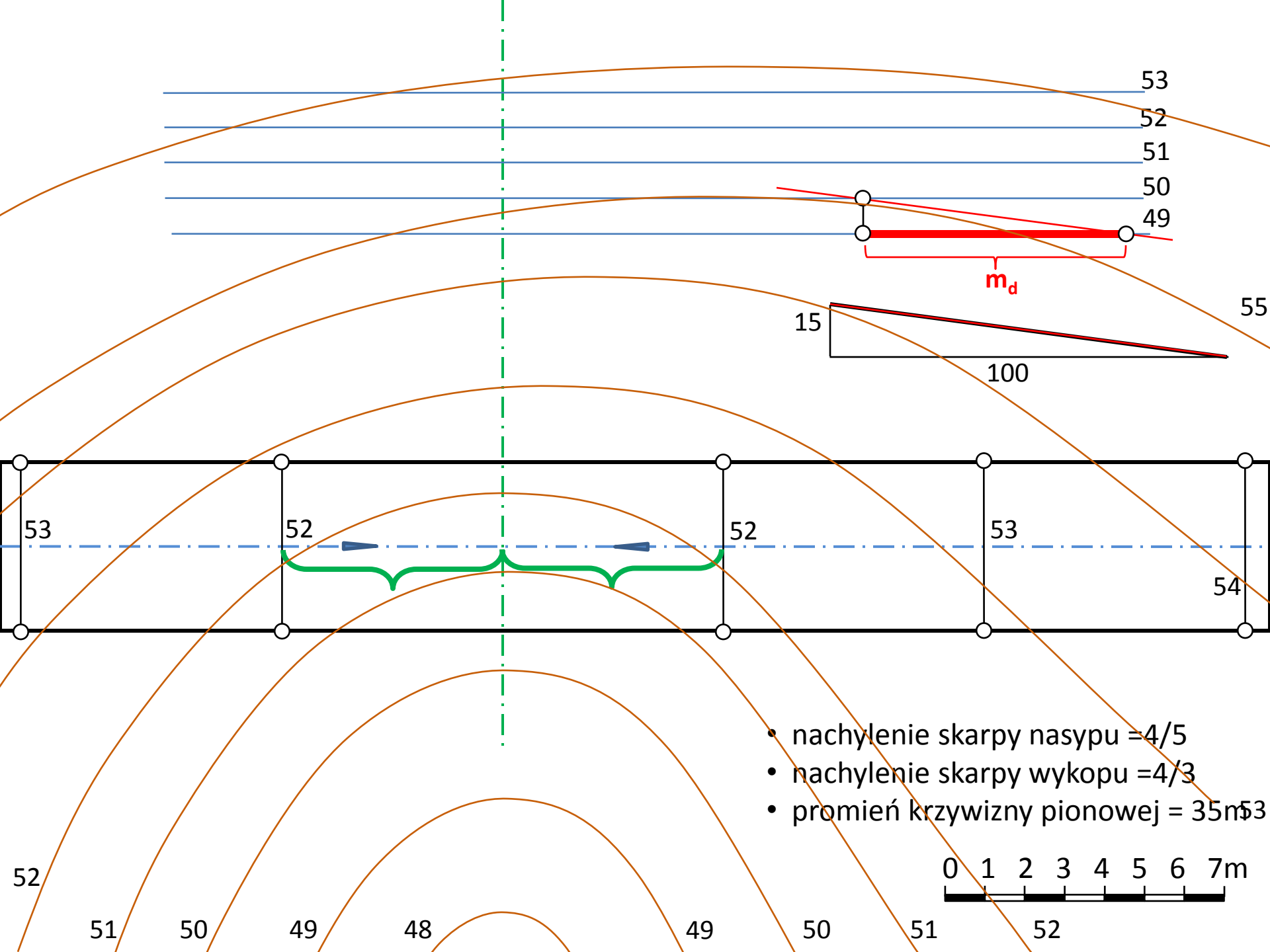

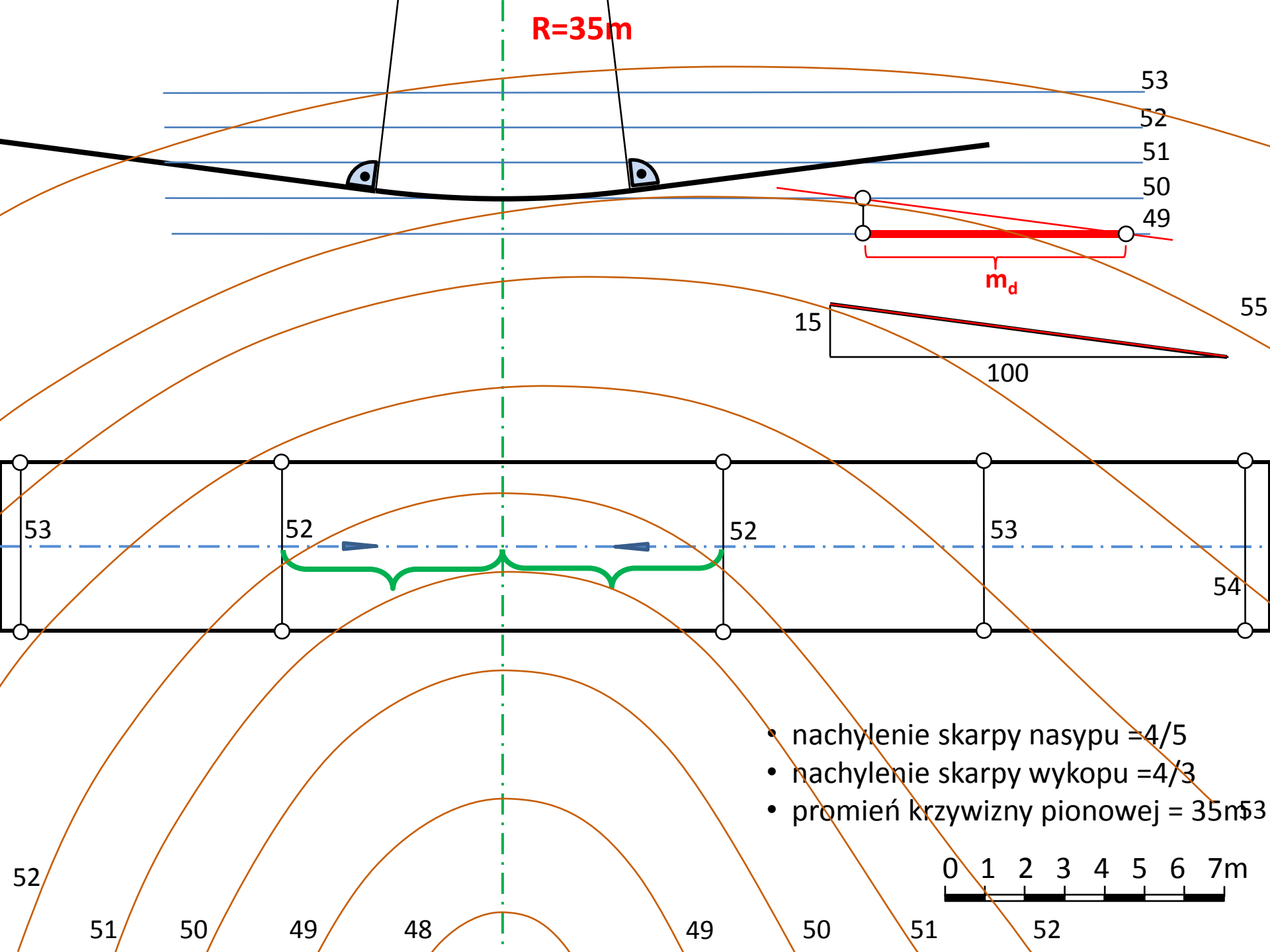

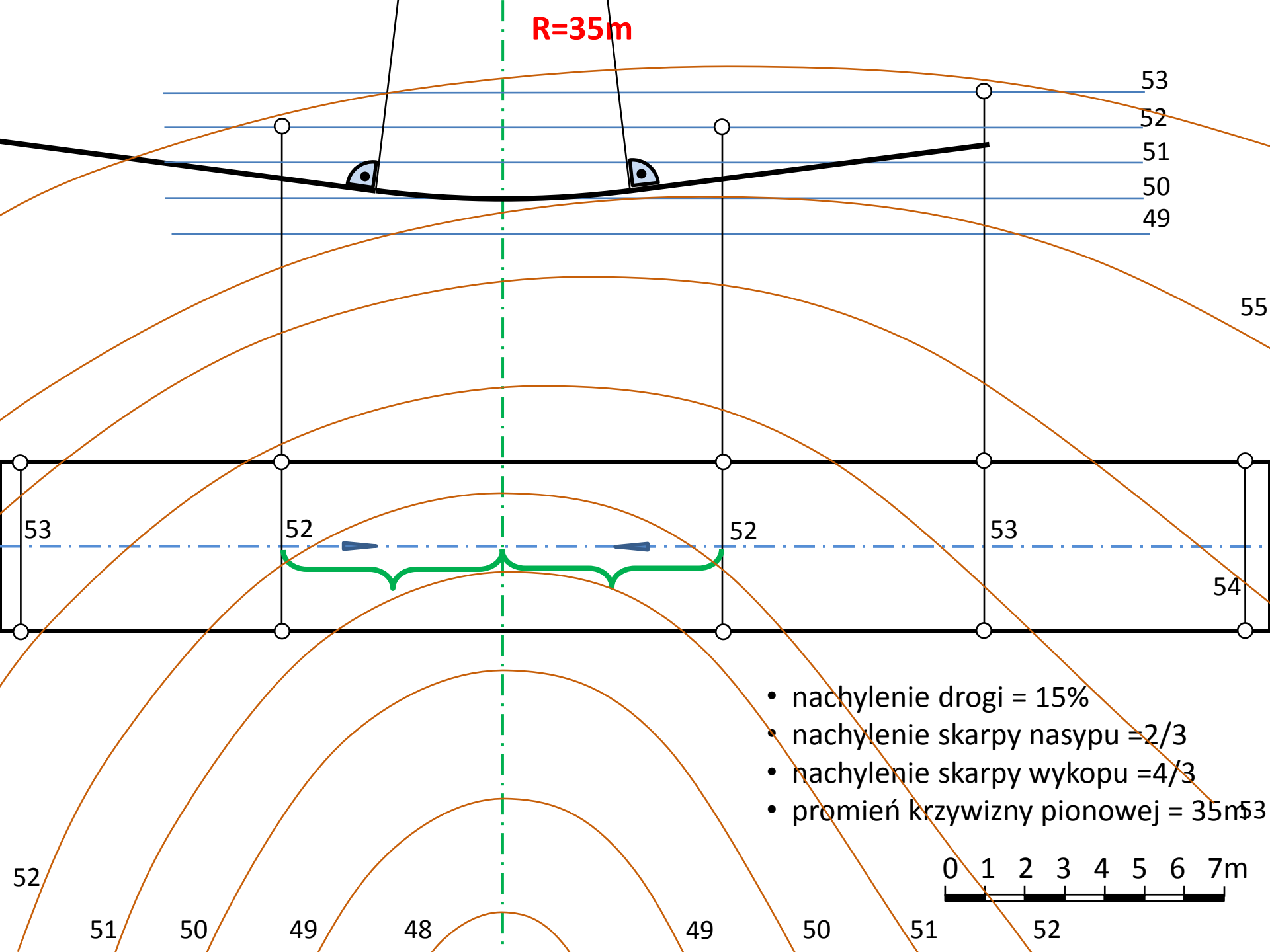

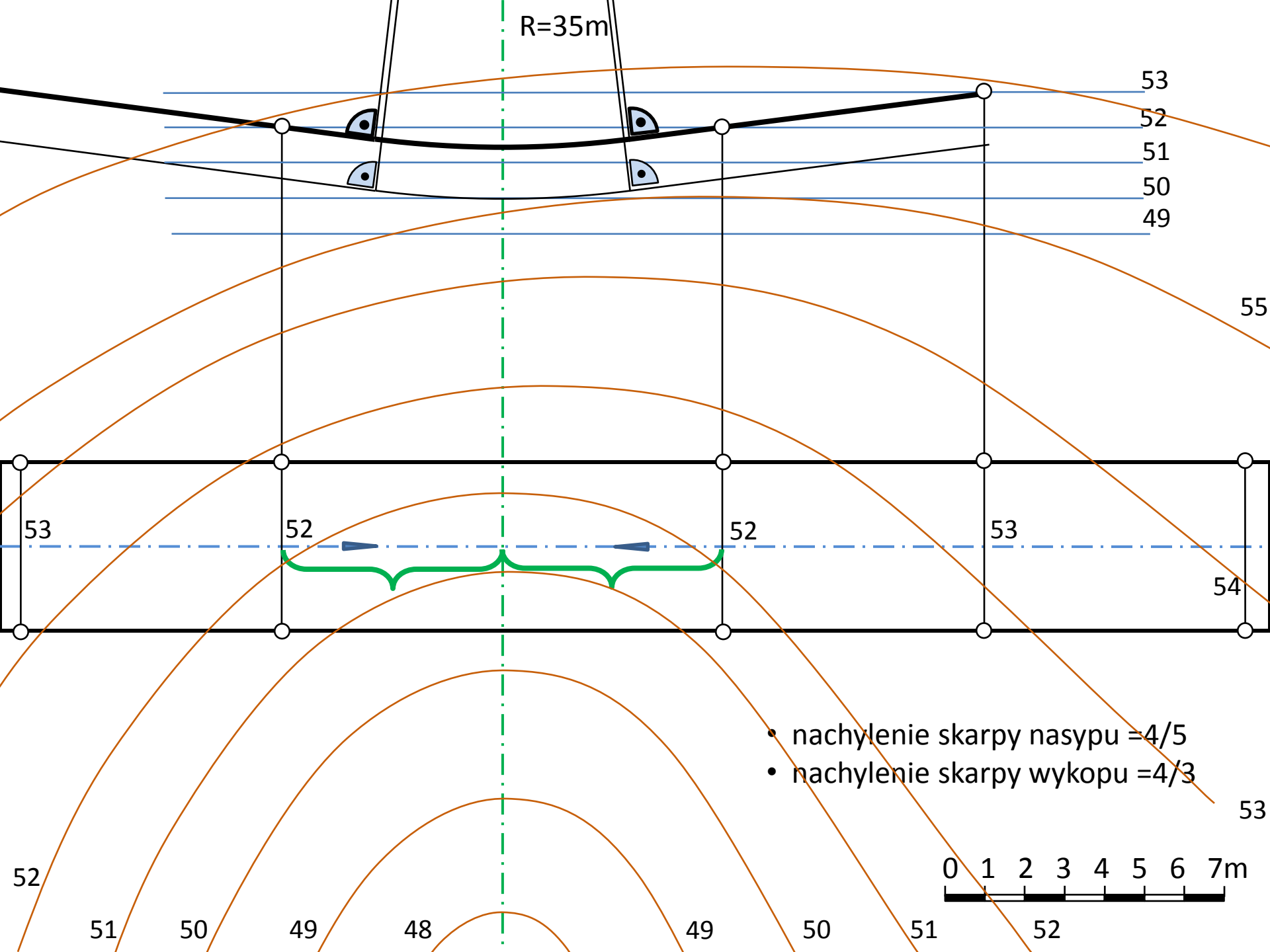

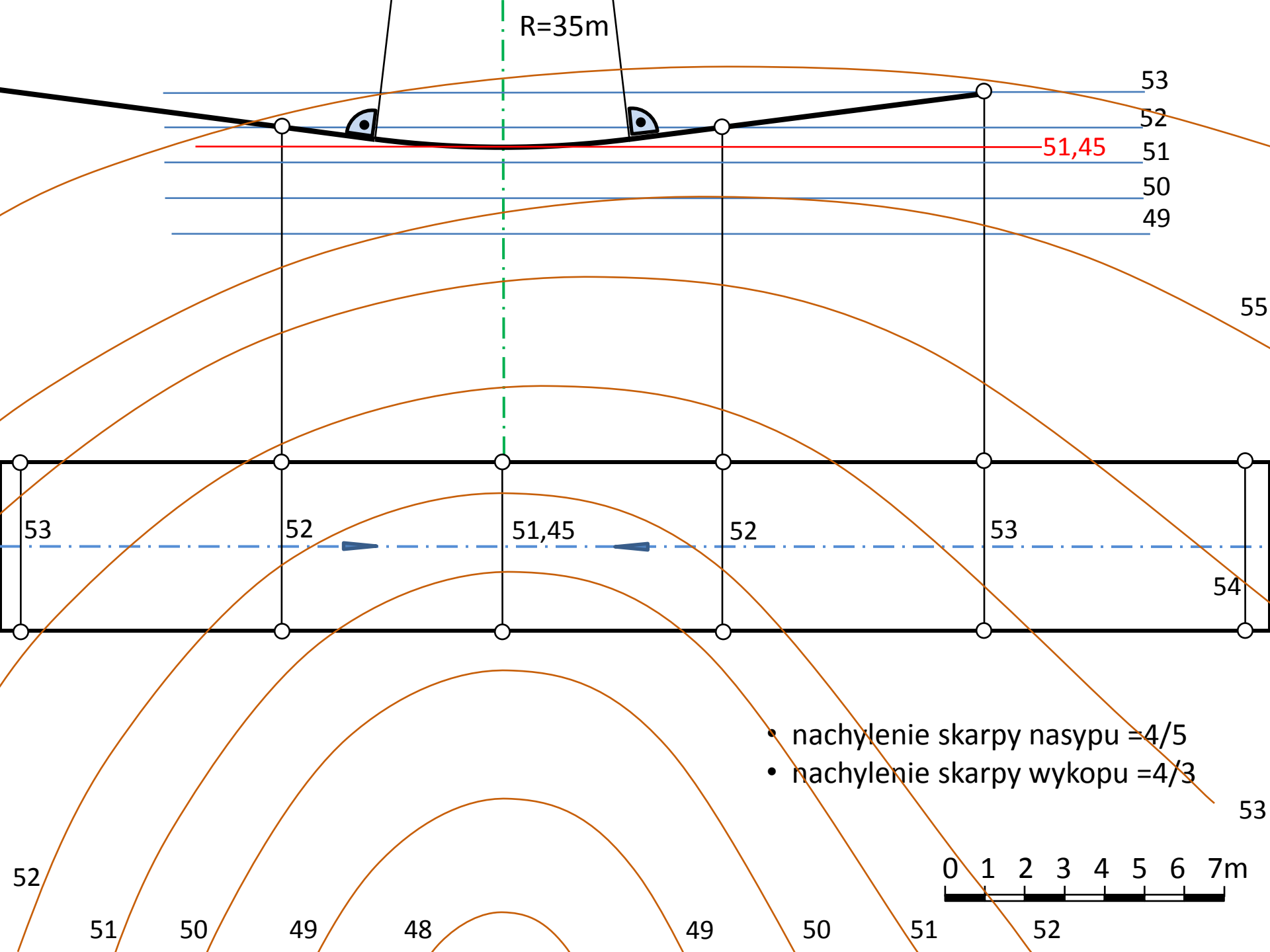

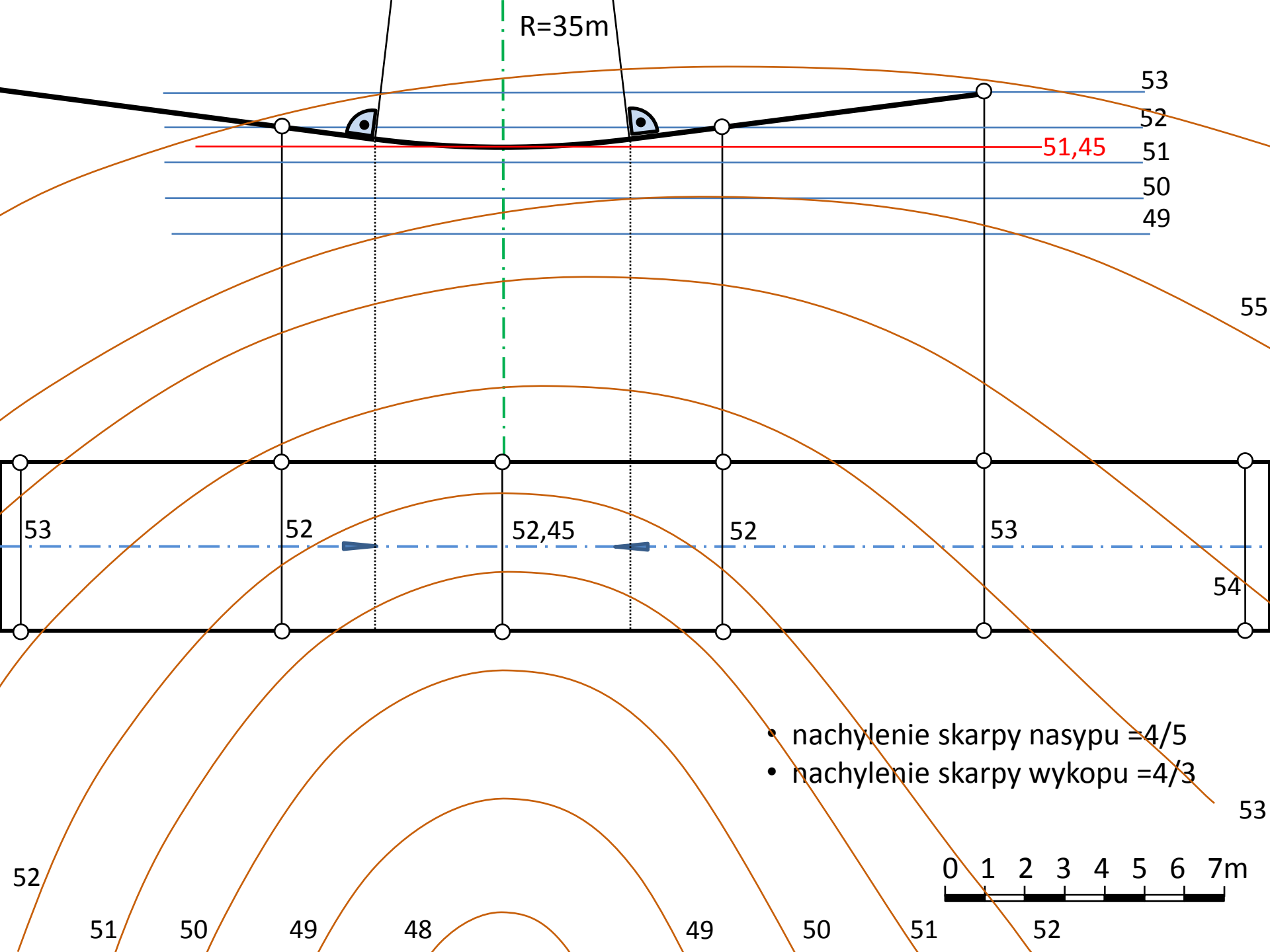

$R=35\text{m}$

$-51,45$

$52,45$

- nachylenie skarpy nasypu $=4/5$
- nachylenie skarpy wykopu $=4/3$

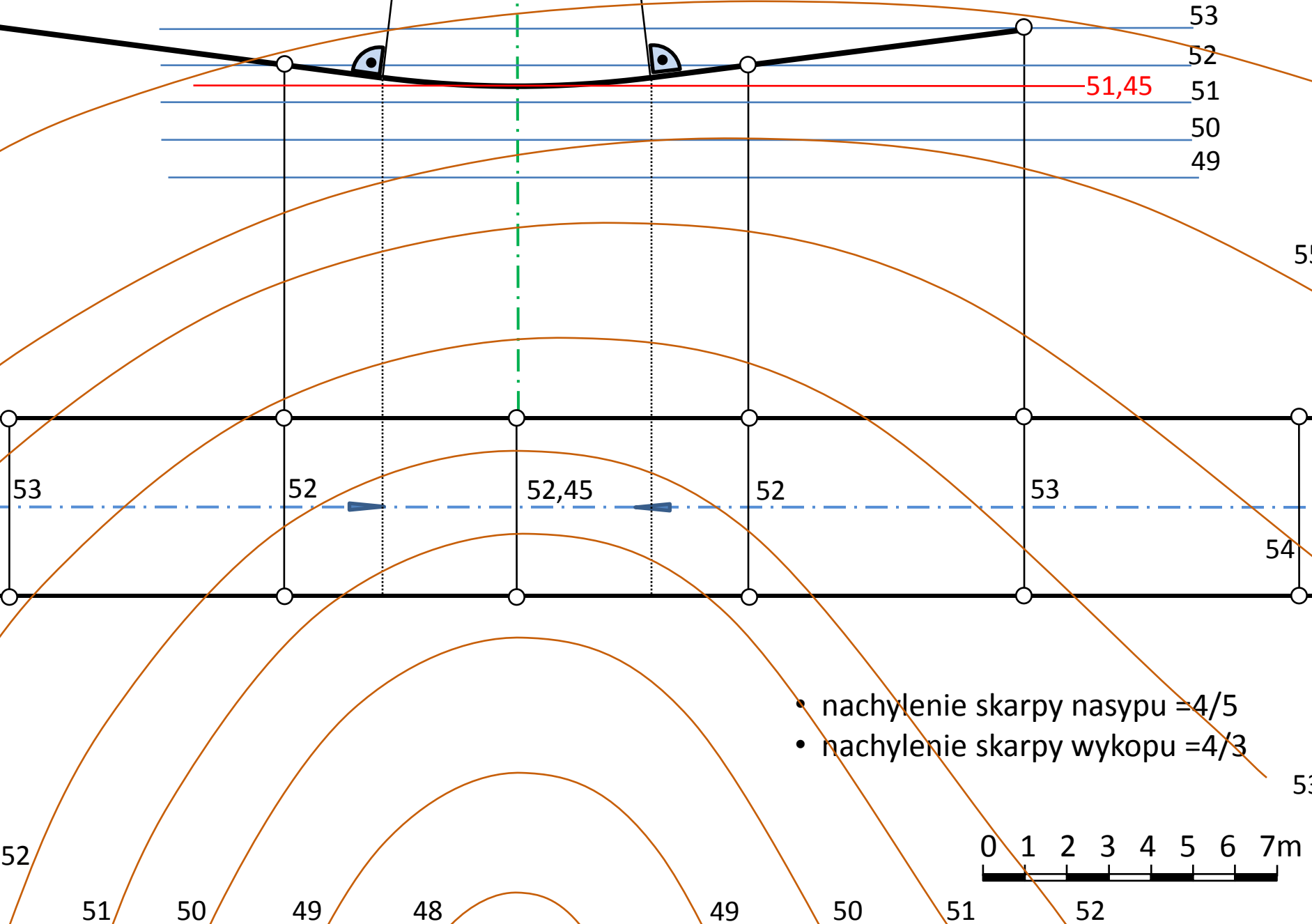
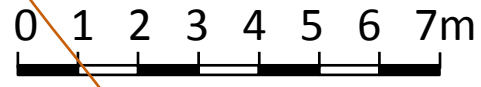

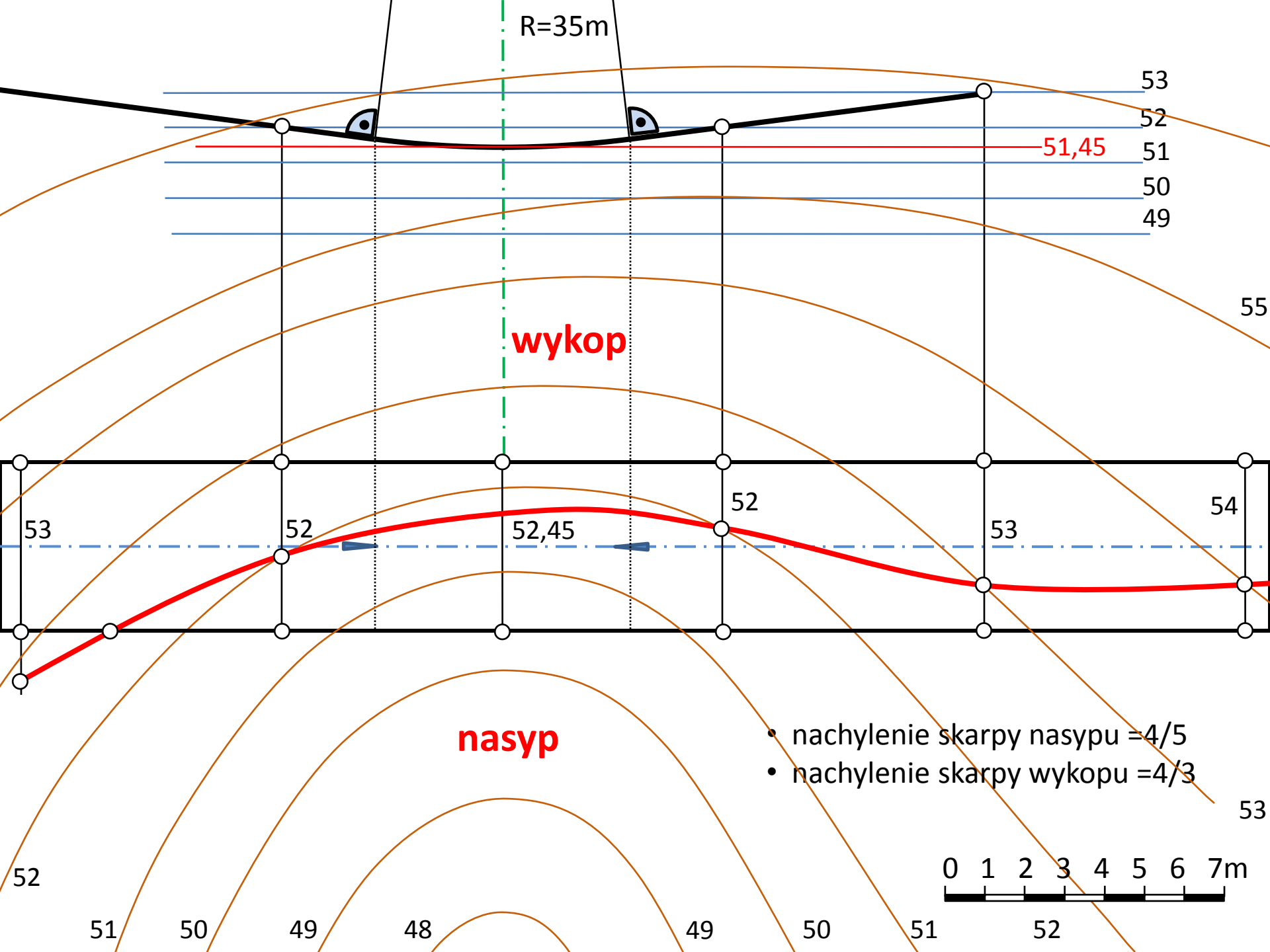

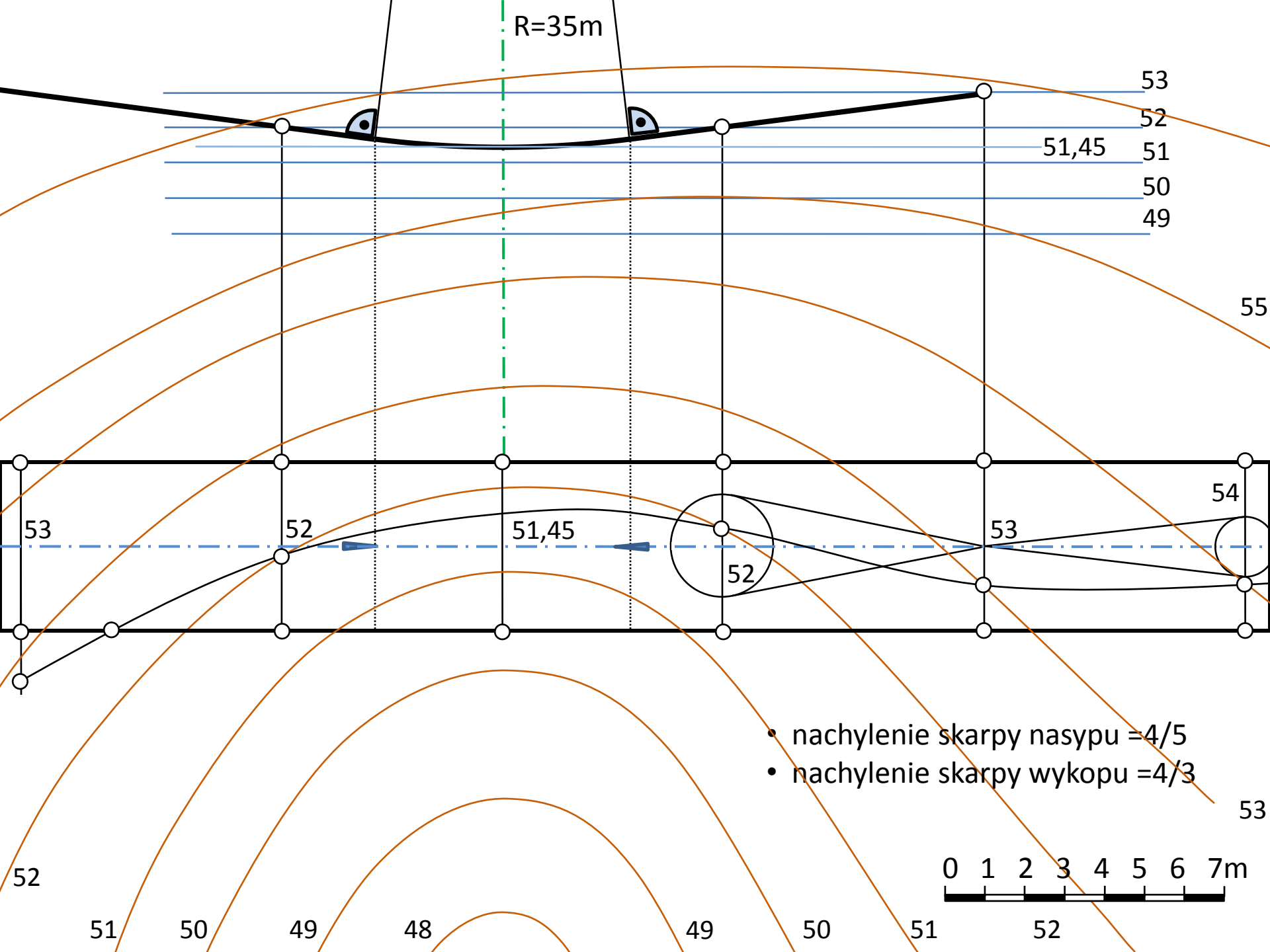

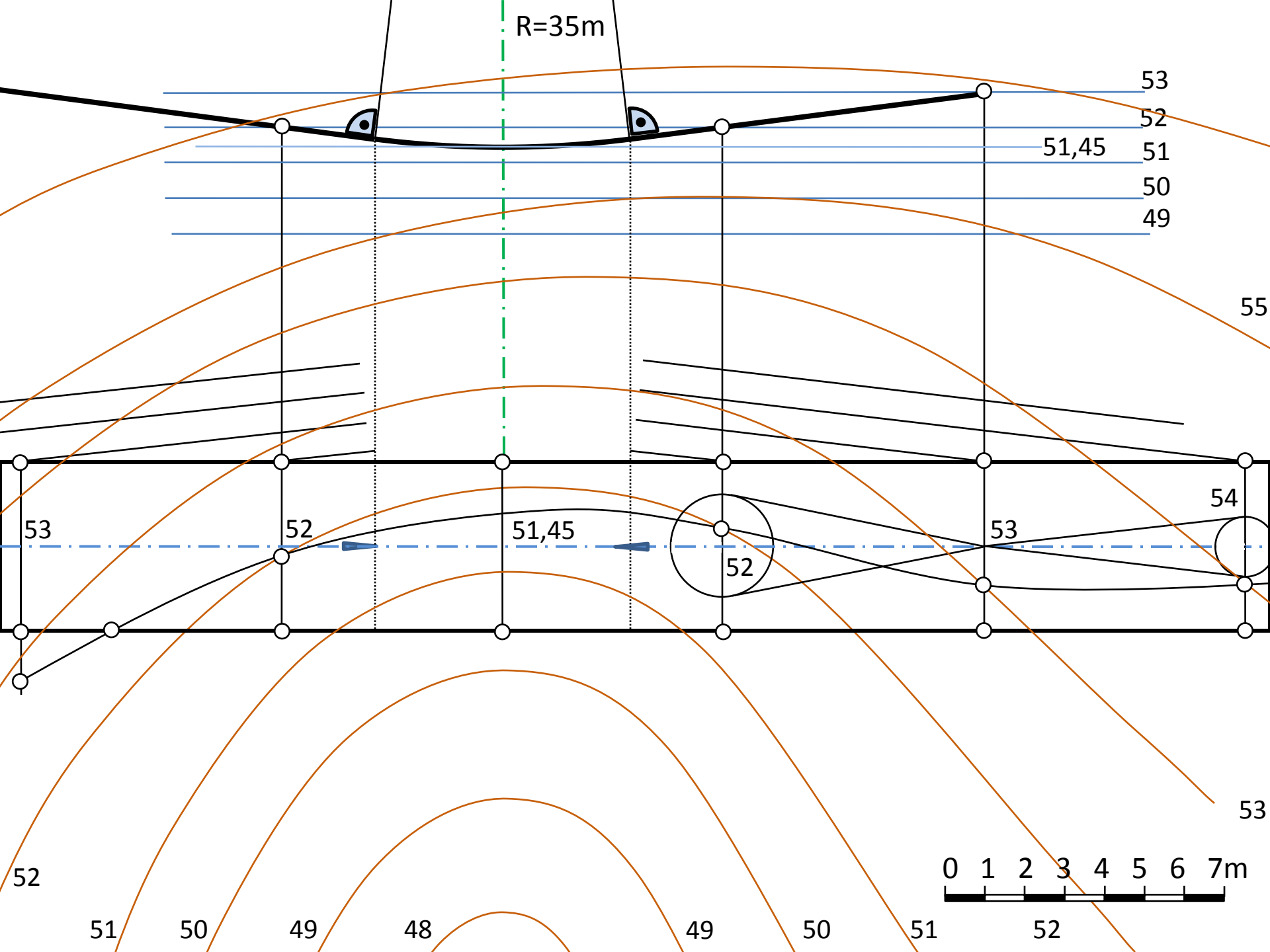

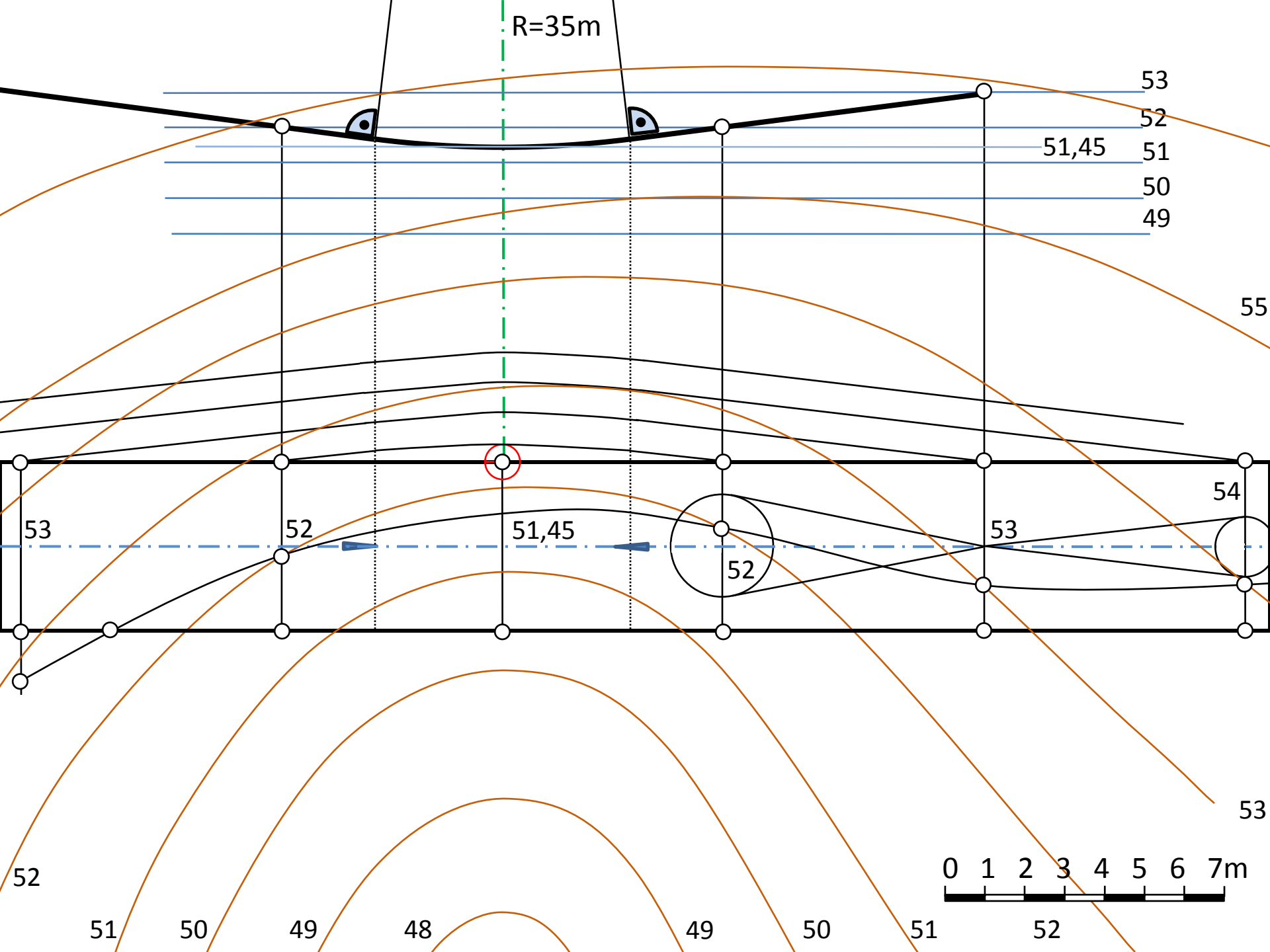

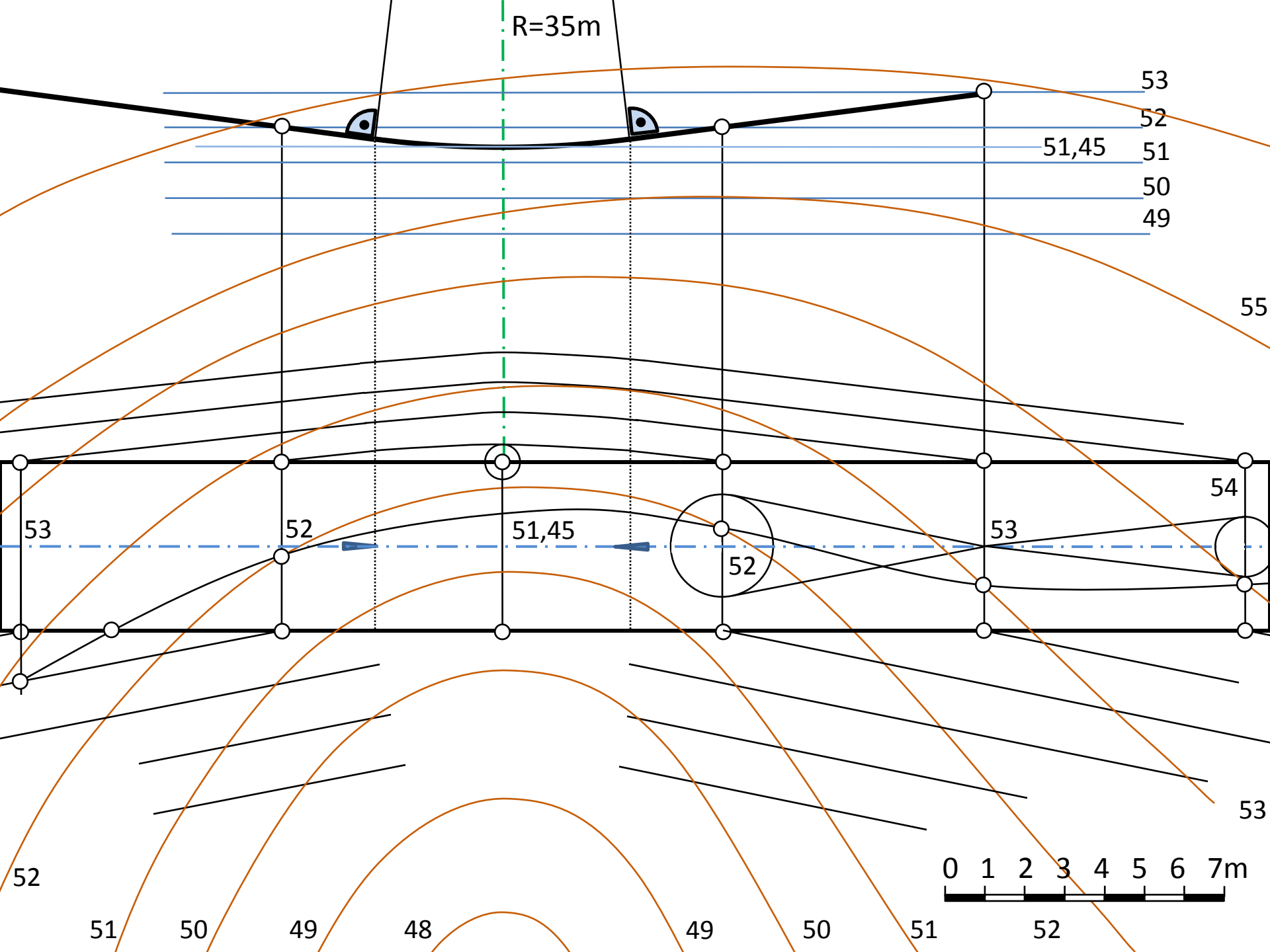

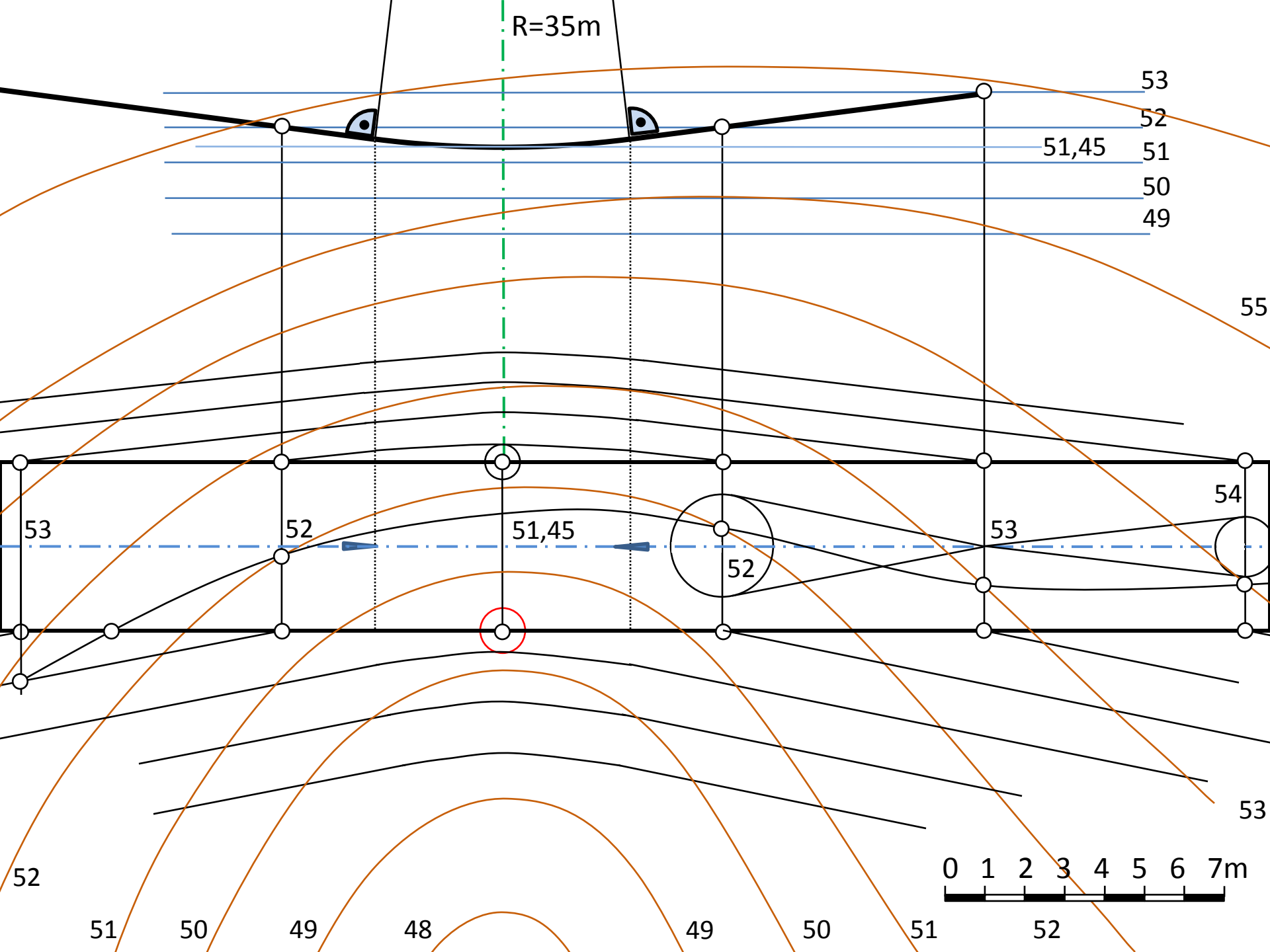

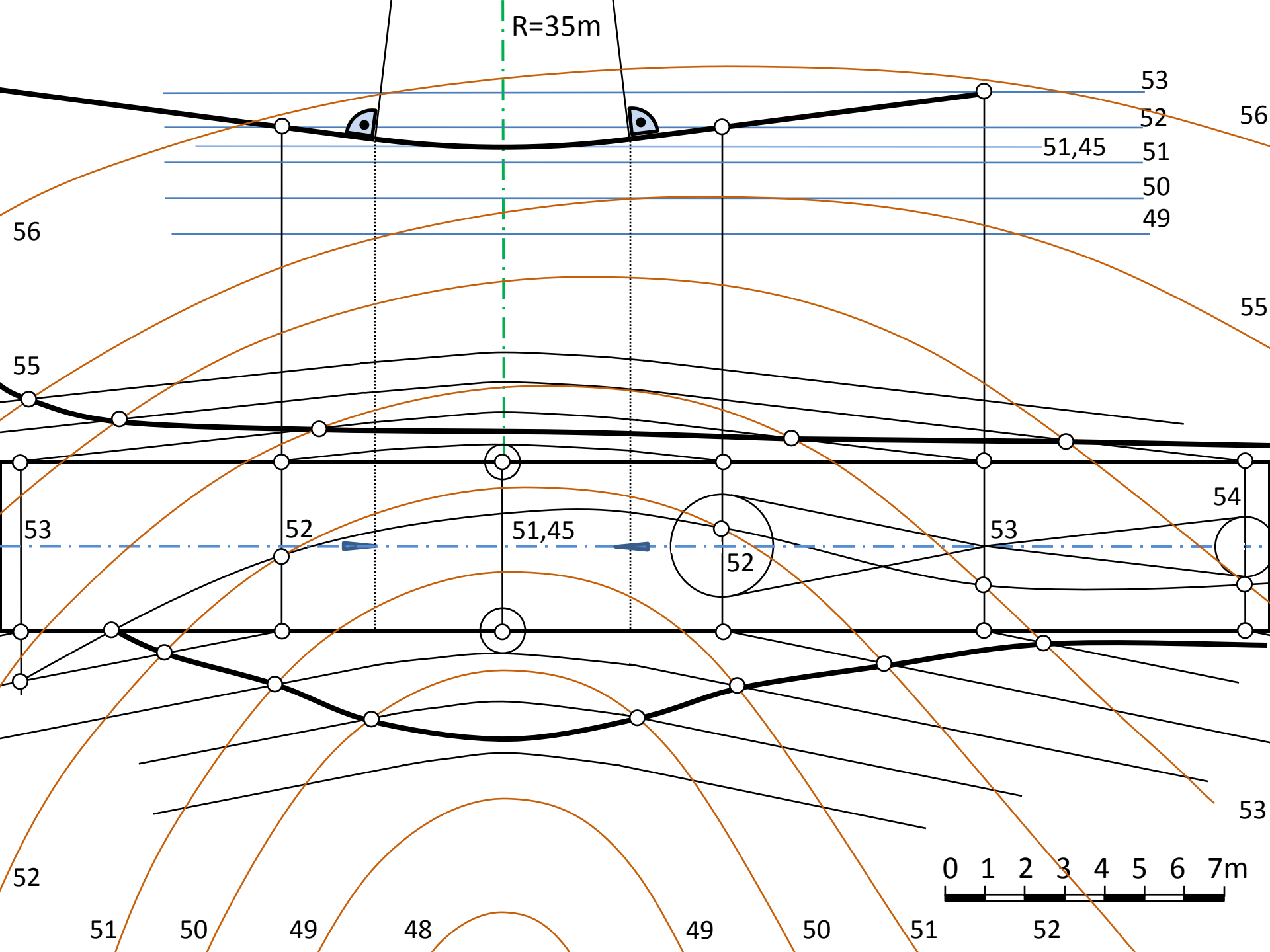

PROJEKT PLACU Z DROGĄ DOJAZDOWĄ

- nachylenie drogi = 15%
- nachylenie skarpy nasypu = 2/3
- nachylenie skarpy wykopu = 4/3
- promień krzywizny pionowej = 35m

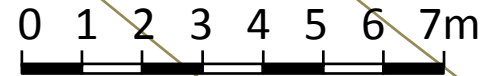
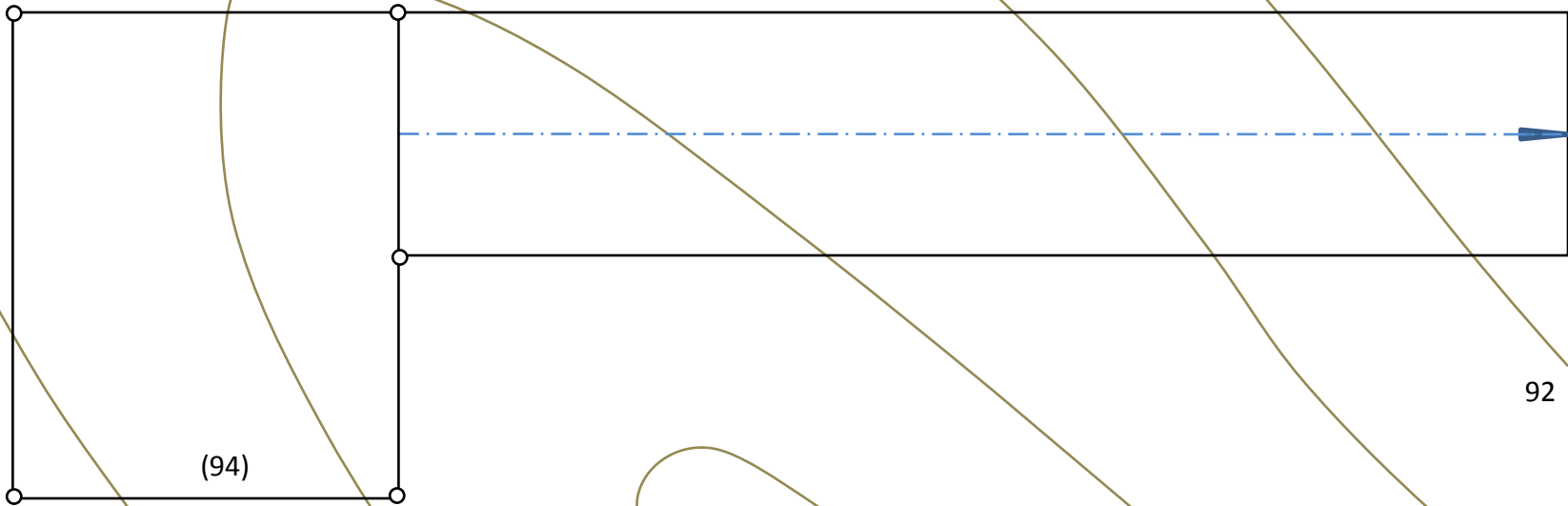

93

92

91

90

89

88

89

90

Połączenie odcinków dróg o przeciwnym spadku

- nachylenie drogi = 15%
- nachylenie skarpy nasypu = 4/5
- nachylenie skarpy wykopu = 4/3
- promień krzywizny pionowej = 35m

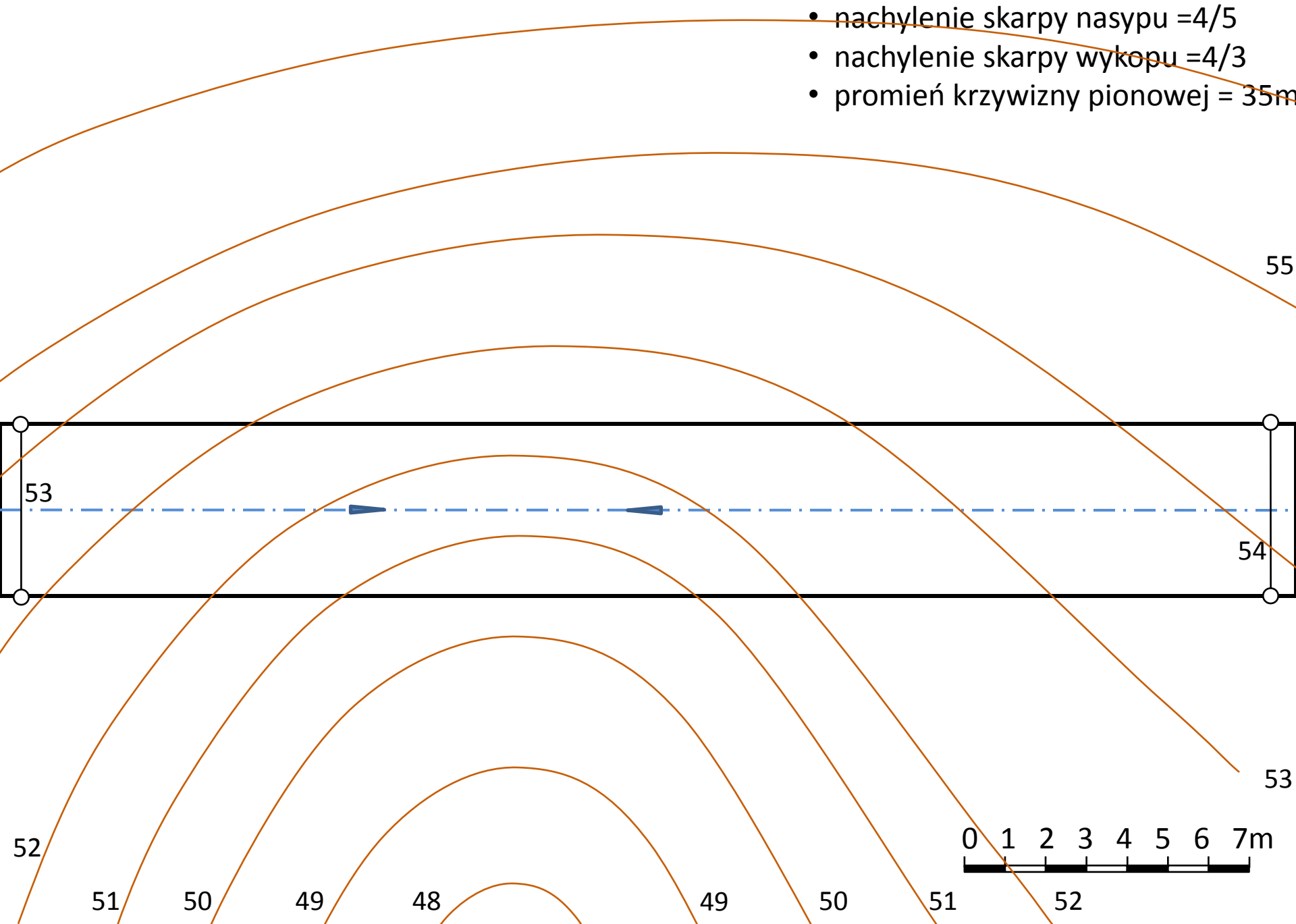



Iwan KERNICKI

Projektowanie geometryczne placów budowlanych i dróg dojazdowych

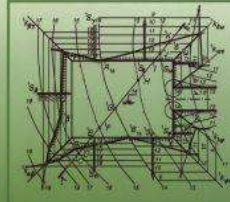
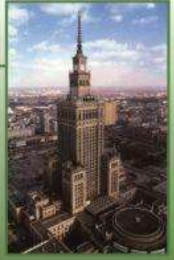

WYDAWNICTWO SGGW

Literatura:

- Iwan Kernicki, *Projektowanie geometryczne placów budowlanych i dróg dojazdowych*. Wydawnictwo SGGW, Warszawa 2008
- Literatura: Jerzy Waligórski, *Zasady i zastosowania rzutu cechowanego*, PWN Warszawa, 1961
- M. Helenowska–Peschke, K. Przyłucka, *Wykłady z geometrii wykreślnej*, www.pg.gda.pl/~mhelen/w1/
- M. Helenowska–Peschke, A. Wancław, *Geometria wykreślna w zadaniach*, <http://pbc.gda.pl/dlibra/>
- M. Helenowska–Peschke, K. Przyłucka, *Ćwiczenia z geometrii wykreślnej*, <http://pbc.gda.pl/dlibra/>
- Bożena Kotarska-Lewandowska *GEOMETRIA WYKREŚLNA. ZADANIA TESTOWE*

http://pbc.gda.pl/dlibra/docmetadata?id=9921&from=&dirids=1&ver_id=&lp=1&QI=

<http://pbc.gda.pl/dlibra/doccontent?id=2594&dirids=16> (przebieg drogi w terenie)

<http://pbc.gda.pl/dlibra/doccontent?id=2566&dirids=16> (rzut cechowany – 7 zadań)