



Fundusze
Europejskie
Wiedza Edukacja Rozwój

Unia Europejska
Europejski Fundusz Społeczny



STRUCTURAL SAFETY

The term *structural reliability* should be considered as having two meanings - a general one and a mathematical one.

- In the most general sense, the *reliability* of a structure is its ability to fulfill its design purpose for some specified time.
- **In a narrow sense it is the *probability* that a structure will not attain each specified limit state (ultimate or serviceability) during a specified *reference period*.**



**Fundusze
Europejskie**
Wiedza Edukacja Rozwój

Unia Europejska
Europejski Fundusz Społeczny



Here we shall be concerned with structural reliability in the narrow sense and shall generally be treating each limit state or failure mode separately and explicitly.

Most structures and structural elements have a **number of possible failure modes**, and in determining the overall reliability of a structural system this must be taken into account making due allowance for the correlations arising from common sources of loading and common material properties.

Reference period – in general, structural reliability is dependent on time of exposure to the loading environment.

It is also affected if material properties change with time.



Example 1.2. Assume that an offshore structure is idealised as a uniform vertical cantilever rigidly connected to the sea bed. The structure will fail when the moment S induced at the root of the cantilever exceeds the flexural strength R . Assume further that R and S are random variables whose statistical distributions are known very precisely as a result of a very long series of measurements. R is a variable representing the variations in strength between nominally identical structures, whereas S represents the maximum load effects in successive T year periods. The distributions of R and S are both assumed to be stationary with time. Under these assumptions, the probability that the structure will collapse during any reference period of duration T years is given by

$$P_f = P(M \leq 0) = \int_{-\infty}^{+\infty} F_R(x) f_S(x) dx$$



Fundusze
Europejskie
Wiedza Edukacja Rozwój

Unia Europejska
Europejski Fundusz Społeczny



where

$$M = R - S$$

and F_R is the probability distribution function of R and F_S the probability density function of S .

The reliability \mathcal{R} is defined as

$$\mathcal{R} = 1 - P_f$$

may be interpreted as a long-run survival frequency or long-run reliability and is the percentage of a notionally infinite set of nominally identical structures which survive for the duration of the reference period T .

\mathcal{R} may therefore be called a *frequencies reliability*.

If, however, we are forced to focus our attention on one particular structure (and this is generally the case for civil engineering



**Fundusze
Europejskie**
Wiedza Edukacja Rozwój

Unia Europejska
Europejski Fundusz Społeczny



structures), \mathcal{R} may also be interpreted as a measure of the reliability of that particular structure.

The associated reliability can be called a subjective or *Bayesian reliability*.

For a particular structure, the numerical value of this reliability changes as the state of knowledge about the structure changes, for example, if non-destructive tests were to be carried out on the structure to estimate the magnitude of r .

In the limit when r becomes known exactly, the probability of failure given changes

$$P_f = P(r - S \leq 0) = 1 - F_S(r)$$



**Fundusze
Europejskie**
Wiedza Edukacja Rozwój

Unia Europejska
Europejski Fundusz Społeczny



This special case may also be interpreted as a *conditional failure probability* with a relative frequency interpretation, i.e.

$$P_f = P(R - S \leq 0 | R = r)$$

Methods of Safety Checking

Methods of structural reliability analysis can be divided into two broad classes. These are:

Level 3: Methods in which calculations are made to determine the “exact” probability of failure for a structure or structural component, making use of a full probabilistic description of the joint occurrence of the various quantities which affect the response of the structure and taking into account the true nature of the failure domain.



Fundusze Europejskie
Wiedza Edukacja Rozwój

Unia Europejska
Europejski Fundusz Społeczny



Level 2: Methods involving certain approximate iterative calculation procedures to obtain an approximation to the failure probability of a structure or structural system, generally requiring an idealisation of failure domain and often associated with a simplified representation of the joint probability distribution of the variables.

For the sake of completeness, some mention should also be made of level 1 methods at this stage.

These are not methods of reliability analysis, but are methods of design or safety checking.

Level 1: Design methods in which appropriate degrees of structural reliability are provided on a structural element basis (occasionally on a structural basis) by the use of a number of partial safety factors, or partial coefficients, related to pre-defined characteristic or nominal values of the major structural and loading variables.



Limit states - Definition of Failure

Although it may seem obvious, the term "failure" means different things to different people. We could say that a structure fails if it cannot perform its intended function. However, this is a vague definition because we haven't specified the function of the structure. To illustrate this point, consider a simply supported steel hot-rolled beam such as the one shown in the Figure.

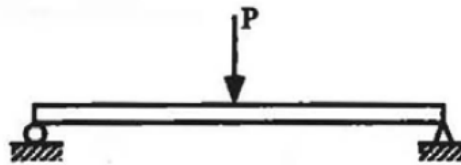
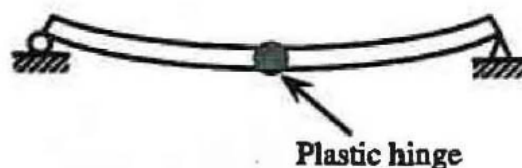

Figure. A simple supported beam.

We could state that the beam fails when the maximum deflection exceeds $\delta_{critical}$.



However, a steel beam may "fail" by developing a plastic hinge, losing overall stability, or by local buckling of the compression flange or web.



Development of a plastic hinge in a beam

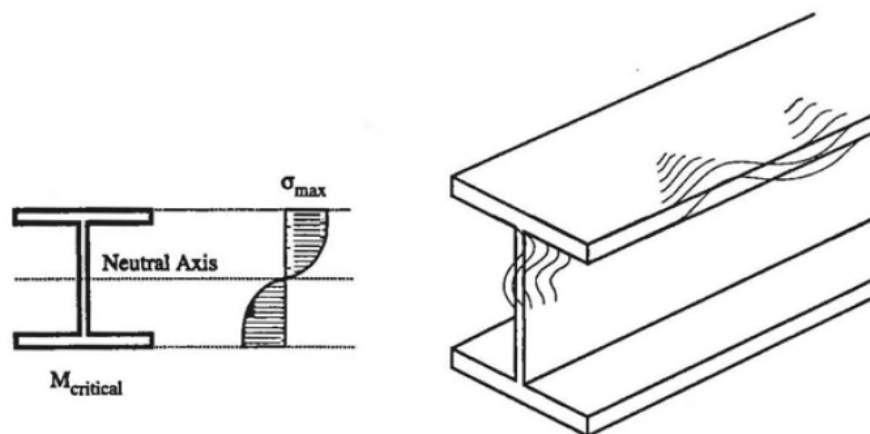

Local buckling in a steel beam.



Fundusze Europejskie
Wiedza Edukacja Rozwój

Unia Europejska
Europejski Fundusz Społeczny



It is obvious that the term "failure" can have different - meanings. Before attempting a structural reliability analysis, failure must be clearly defined.

The concept of a **limit state** is used to help define failure in the context of structural reliability analyses.

A *limit state* is a boundary between desired and undesired performance of a structure.

This boundary is often represented mathematically by a *limit state function* or *performance function*.

For example, in bridge structures, failure could be defined as the inability to carry traffic.

This undesired performance can occur by many modes of failure: cracking, corrosion, excessive deformations, exceeding load-carrying capacity for shear or bending moment, or local or overall buckling.



Fundusze Europejskie
Wiedza Edukacja Rozwój

Unia Europejska
Europejski Fundusz Społeczny



Some members may fail in a brittle manner, whereas others may fail in a ductile fashion.

In the traditional approach, each mode of failure is considered separately, and each mode can be defined using the concept of a limit state.

In structural reliability analyses three types of limit states are considered:

1. Ultimate limit states (ULSs) are mostly related to the loss of load-carrying capacity.

Examples of modes of failure in this category include:

Exceeding the moment carrying capacity

Formation of a plastic hinge.

Crushing of concrete in compression

Shear failure of the web in a steel beam

Loss of the overall stability



Fundusze Europejskie
Wiedza Edukacja Rozwój

Unia Europejska
Europejski Fundusz Społeczny



Buckling of web
Weld rupture.

2. Serviceability limit states (SLSs) are related to gradual deterioration, user's comfort, or maintenance costs. They may or may not be directly related to structural integrity. Examples of modes of failure include:

Excess deflection.

Deflection is a rather controversial limit state.

The acceptable limits are subjective, and they may depend on human perception.

A building with visible deflections (horizontal or vertical) is not acceptable by the public, even though it may be structurally safe.

Excessive deflections may interfere with the operation of precise instruments sensitive to movement.



**Fundusze
Europejskie**
Wiedza Edukacja Rozwój

Unia Europejska
Europejski Fundusz Społeczny



For example, for bridge girders, the current practice is to limit deflections to a fraction of the span length; for example, $L/800$, where L = span length.

The deflection limit often governs the design.

Excess vibration.

Vibration is another serviceability limit state that is difficult to quantify.

The acceptability criteria are also highly subjective and often depend on human perception.

In a building, the occupants may not tolerate excessive vibration; a vibrating bridge, however, may be acceptable if pedestrians are not involved.

The design for vibration may require a complicated dynamic analysis. In many current design codes, vibration is not considered in a direct form. Indirectly, the codes impose a limit on static deflection, and this is also intended to serve as a limit for vibration.



Permanent deformations.

Each time the load exceeds the elastic limit, a permanent deformation may result.

Accumulation of these permanent deformations can lead to serviceability problems.

Therefore, in some design codes, a limit is imposed on permanent deformations.

For example, consider a multispan bridge with continuous girders as shown in Figure.

Each time the strain exceeds the yield strain, there is some permanent strain left in the section.

This strain accumulates and eventually causes the formation of a "kink," as shown in the next Figure.



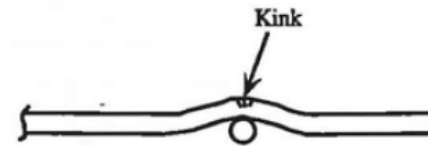
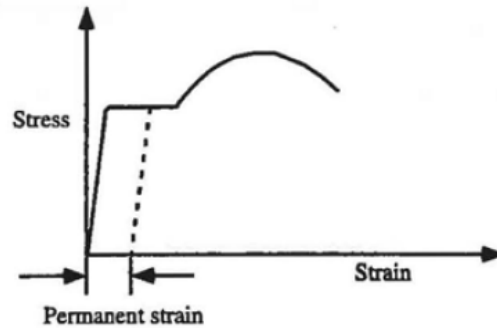

Cracking.

Cracks, such as those shown in Figure, by themselves do not necessarily affect the structural performance of concrete structures.

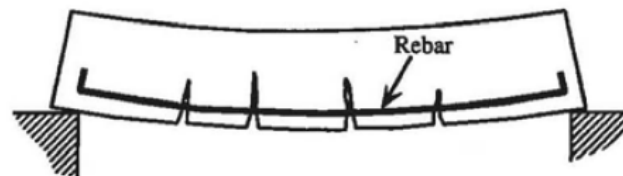

However, they lead to steel corrosion, spalled concrete, salt (deicing agent) penetration, and irreversible loss of concrete tensile strength.



Fundusze Europejskie
Wiedza Edukacja Rozwój

Unia Europejska
Europejski Fundusz Społeczny



To define acceptable cracking standards, many questions must be answered.

What is acceptable with regard to cracking?

Are acceptable cracks limited by size?

Width?

Length?

How frequently can the cracks open?

3. Fatigue limit states (FLSs) are related to loss of strength under repeated loads.

Fatigue limit states are related to the accumulation of damage and eventual failure under repeated loads.

It has been observed that a structural component can fail under repeated loads at a level lower than the ultimate load.

The failure mechanism involves the formation and propagation of cracks until their rupture.



**Fundusze
Europejskie**
Wiedza Edukacja Rozwój

Unia Europejska
Europejski Fundusz Społeczny



This may result in structural collapse.

Fatigue limit states occur in steel components and reinforcement bars in concrete, particularly those in tension.

Welding affects the fatigue resistance of components and connections.

Fatigue failures have also been reported in the prestressing strands of posttensioned concrete bridges.

In any fatigue analysis, the critical factors are both the magnitude and frequency of load.



Limit State Functions (performance functions)

A traditional notion of the "safety margin" or "margin of safety" is associated with the ultimate limit states.

For example, a mode of beam failure could be when the moment due to loads exceeds the moment-carrying capacity.

Let R represent the resistance (moment-carrying capacity) and Q represent the load effect (total moment applied to the considered beam).

It is sometimes helpful to think of R as the "capacity" and Q as the "demand."

A *performance function*, or *limit state function*, can be defined for this mode of failure as

$$g(R, Q) = R - Q \quad (0.1)$$

The *limit state*, corresponding to the boundary between desired and undesired performance, would be when $g = 0$.



If $g \geq 0$, the structure is safe (desired performance); if $g < 0$, the structure is not safe (undesired performance).

The probability of failure, P_f , is equal to the probability that the undesired performance will occur.

Mathematically, this can be expressed in terms of the performance function as

$$P_f = P(R - Q < 0) = P(g < 0) \quad (0.2)$$

If both R and Q are continuous random variables, then each has a probability density function (pDF) such as shown in Figure.

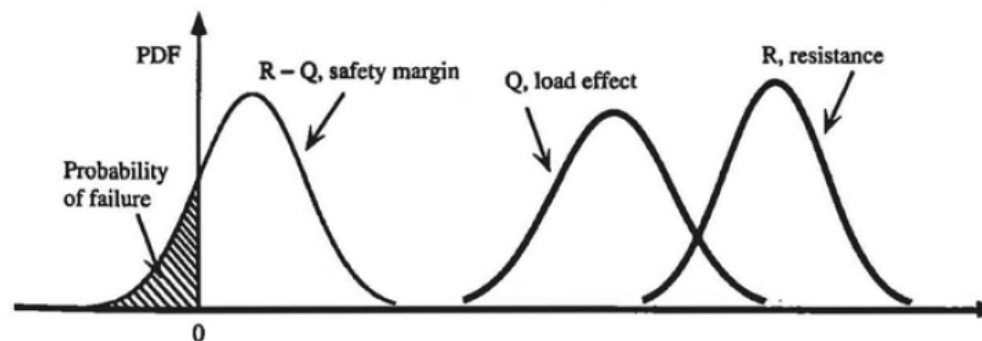



Fundusze Europejskie
Wiedza Edukacja Rozwój

Unia Europejska
Europejski Fundusz Społeczny



Furthermore, the quantity $R - Q$ is also a random variable with its own PDF.

This is also shown in Figure. The probability of failure corresponds to the shaded area in Figure.

Now let's generalize the concepts just introduced.

All realizations of a structure can be put into one of two categories:

Safe (load effect \leq resistance)

Failure (load effect $>$ resistance)

The state of the structure can be described using various parameters X_1, X_2, \dots, X_n , which are load and resistance parameters such as dead load, live load, length, depth, compressive strength, yield strength, and moment or inertia.



A limit state function, or performance function, is a function $g(X_1, X_2, \dots, X_n)$ of these parameters such that

$g(X_1, X_2, \dots, X_n) >$ for a safe structure

$g(X_1, X_2, \dots, X_n) =$ border or boundary between safe and unsafe

$g(X_1, X_2, \dots, X_n) <$ for failure

Each limit state function is associated with a particular limit state. Different limit states may have different limit state functions. Here are some examples of limit state functions:

1. Let Q = total load effect (total demand) and R = resistance (or capacity). Then the limit state function can be defined as

$$g(R, Q) = R - Q \quad (0.3)$$

or

$$g(R, Q) = R / Q - 1 \quad (0.4)$$



2. Consider case 1 above for the moment capacity of a compact steel beam.

The moment capacity is $R = F_y Z$ where F_y is the yield stress and Z is the plastic section modulus.

Substituting into Eq. (0.3), we get

$$g(F_y, Z, Q) = F_y Z - Q \quad (0.5)$$

3. Consider case 2 with a more definitive description of the demand. Assume that the total demand or load effect on the beam is made up of contributions from dead load (D), live load (L), wind load (W), and earthquake load (E).

If $Q = D + L + W + E$,

then Eq. (0.5) is

$$g(F_y, Z, D, L, W, E) = F_y Z - D - L - W - E \quad (0.6)$$



**Fundusze
Europejskie**
Wiedza Edukacja Rozwój

Unia Europejska
Europejski Fundusz Społeczny



In general, the performance function (limit state function) can be a function of many variables: load components, influence factors, resistance parameters, material properties, dimensions, analysis factors, and so on.

A direct calculation of P_f using Eq. (0.2) is often very difficult, if not impossible.

Therefore, it is convenient to measure structural safety in terms of a **reliability index**.



FUNDAMENTAL CASE

Probability of Failure

We now examine how to determine the probability of failure for the relatively simple performance function given earlier by

$$g(R, Q) = R - Q \quad (0.7)$$

The probability of failure, P_f , can be derived by considering the PDFs of the random variables R and Q as shown in Figure.

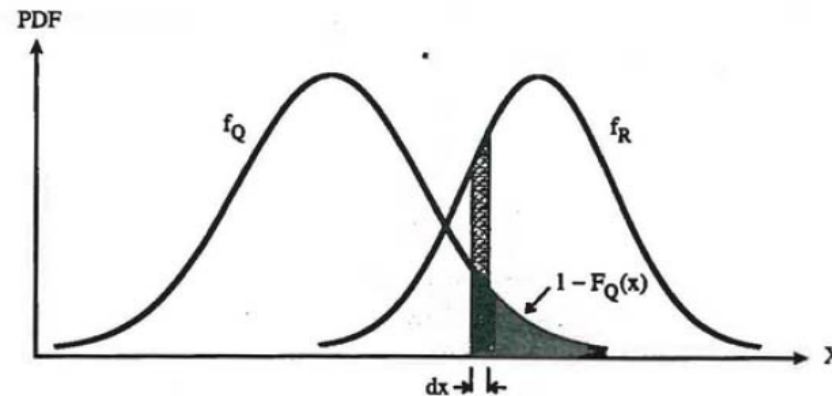

PDFs of load (Q) and resistance (R).

The structure "fails" when the load exceeds the resistance.



If R is equal to a specific value r_i , then the probability of failure is equal to the probability that the load is greater than the resistance, or $P(Q > r_i)$.

However, since R is a random variable, there is a probability associated with each r_i value.

Therefore, the probability of failure is composed of all possible combinations of $R = r_i$ and $Q > r_i$, which can be written as

$$P_f = \sum P(R = r_i \cap Q > r_i) = \sum P(Q > r_i | R = r_i) P(R = r_i) \quad (0.8)$$

where the properties of conditional probability have been used in.

For the continuous case, the summation becomes an integral.

The probability $P(Q > R | R = r_i)$ is simply

$$1 - P(Q \leq R | R = r_i) = 1 - F_Q(r_i)$$

In the limit, the probability $P(R = r_i) \approx f_R(r_i) dr_i$.



Combining all these modifications into Eq. (0.8) leads to

$$P_f = \int_{-\infty}^{\infty} [1 - F_Q(r_i)] f_R(r_i) dr_i = 1 - \int_{-\infty}^{\infty} F_Q(r_i) f_R(r_i) dr \quad (0.9)$$

There is an alternative formulation that we can use.

If the load Q is equal to a specific value q_i , then the probability of failure is equal to the probability that the resistance is less than the load, or $P(R < q_i)$.

However, since Q is a random variable, there is a probability associated with each q_i value.

Therefore, the probability of failure is composed of all possible combinations of $Q = q_i$ and $R < q_i$, which can be written as

$$P_f = \sum P(Q = q_i \cap R < q_i) = \sum P(R < Q | Q = q_i) P(Q = q_i) \quad (0.10)$$



Following the same logic as earlier, this can be written in integral form as

$$P_f = \int_{-\infty}^{\infty} F_R(q_i) f_Q(q_i) dq_i \quad (0.11)$$

Although Eqs. (0.9) and (0.11) appear rather straightforward, it is difficult to evaluate these integrals in general.

The integration requires special numerical techniques, and the accuracy of these techniques may not be adequate.

Therefore, in practice, the probability of failure is calculated indirectly using other procedures.

Space of State Variables

To begin our analysis, we need to define the state variables of the problem.

The *state variables* are the basic load and resistance parameters used to formulate the performance function.



For n state variables, the limit state function is a function of n parameters.

If all loads (or load effects) are represented by the variable Q and total resistance (or capacity) by R then the space of state variables is a two-dimensional space as shown in Figure.

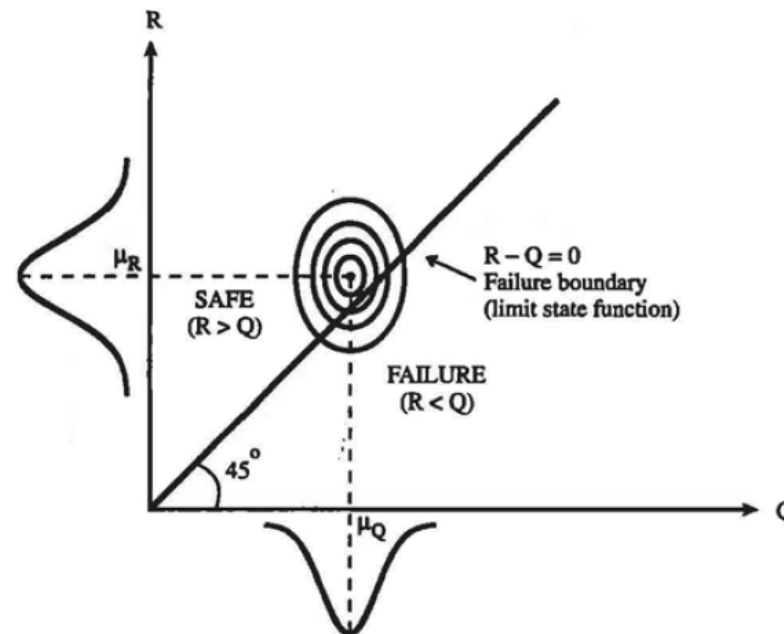

Safe domain and failure domain in a two-dimensional state space.



Within this space, we can separate the "safe domain" from the "failure domain"; the boundary between the two domains is described by the limit state function $g(R, Q) = 0$.

Since both R and Q are random variables, we can define a joint density function $f_{RQ}(r, q)$. A general joint density function is plotted in Figure.

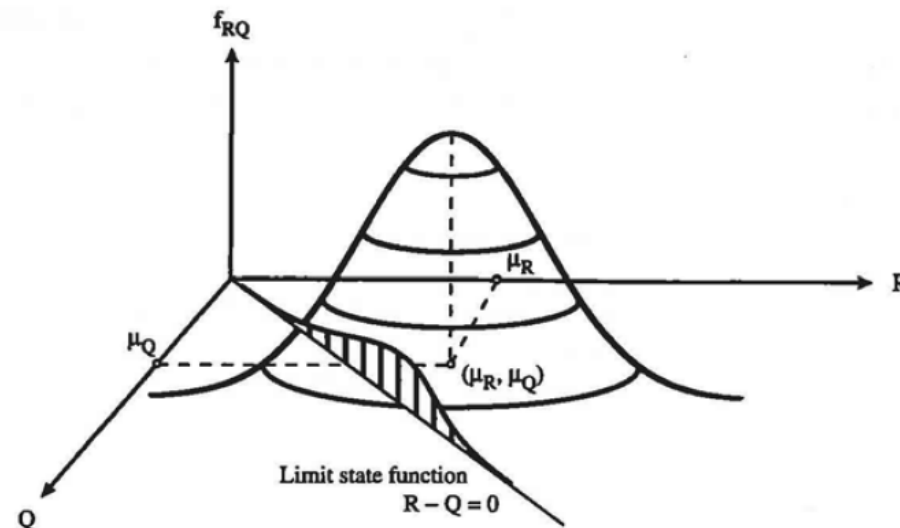

Three-dimensional representation of a possible joint density function f_{RQ} .



**Fundusze
Europejskie**
Wiedza Edukacja Rozwój

Unia Europejska
Europejski Fundusz Społeczny



The limit state function separates the safe and failure domains.

The probability of failure is calculated by integration of the joint density function over the failure domain i.e., the region in which $g(R, Q) < 0$.

As noted earlier, this probability is often very difficult to evaluate, so the concept of a reliability index is used to quantify structural reliability.



RELIABILITY INDEX

Reduced Variables

It will prove convenient in our analysis to convert all random variables to their "standard form," which is a nondimensional form of the variables.

For the basic variables R and Q , the standard forms can be expressed as

$$\begin{aligned} Z_R &= \frac{R - \mu_R}{\sigma_R} \\ Z_Q &= \frac{Q - \mu_Q}{\sigma_Q} \end{aligned} \quad (0.12)$$

The variables Z_R and Z_Q are sometimes called *reduced variables*. By rearranging Eqs. (0.12), the resistance R and the load Q can be expressed in terms of the reduced variables as follows:

$$\begin{aligned} R &= \mu_R + Z_R \sigma_R \\ Q &= \mu_Q + Z_Q \sigma_Q \end{aligned} \quad (0.13)$$



**Fundusze
Europejskie**
Wiedza Edukacja Rozwój

Unia Europejska
Europejski Fundusz Społeczny



The limit state function $g(R, Q) = R - Q$ can be expressed in terms of the reduced variables by using Eqs. 5.12.

The result is

$$g(Z_R, Z_Q) = \mu_R + Z_R \sigma_R - \mu_Q - Z_Q \sigma_Q = (\mu_R - \mu_Q) + Z_R \sigma_R - Z_Q \sigma_Q \quad (0.14)$$

For any specific value of $g(Z_R, Z_Q)$, Eq. (0.14) represents a straight line in the space of reduced variables Z_R and Z_Q .

The line of interest to us in reliability analysis is the line corresponding to $g(Z_R, Z_Q) = 0$ because this line separates the safe and failure domains in the space of reduced variables.



General Definition of the Reliability Index

The reliability index is defined as the *shortest* distance from the origin of reduced variables to the line $g(Z_R, Z_Q) = 0$.

This definition, which was introduced by Hasofer and Lind (1974), is illustrated in Figure.

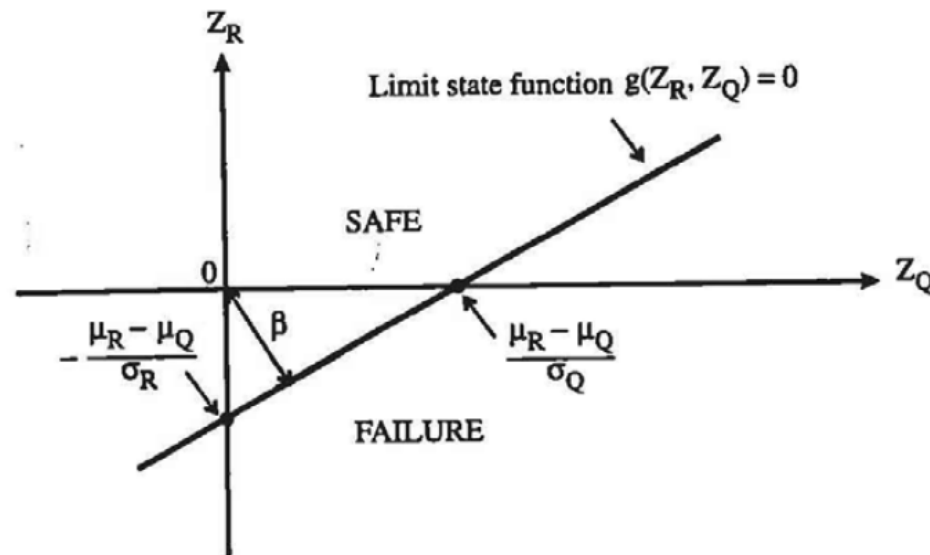

Reliability index defined as the shortest distance in the space of reduced variables.



Using geometry, we can calculate the reliability index (shortest distance) from the following formula:

$$\beta = \frac{\mu_R - \mu_Q}{\sqrt{\sigma_R^2 + \sigma_Q^2}} \quad (0.15)$$

where β is the inverse of the coefficient of variation of the function $g(R, Q) = R - Q$ when R and Q are uncorrelated.

For normally distributed random variables R and Q , it can be shown that the reliability index is related to the probability of failure by

$$\beta = -\Phi^{-1}(P_f) \quad \text{or} \quad P_f = \Phi(-\beta) \quad (0.16)$$

Table 5.1 provides an indication of how β varies with P_f and vice versa based on Eq. 5.15.



Table 5.1 provides an indication of how β varies with P_f and vice versa based on Eq. 5.15.

P_f	β
10^{-1}	1.28
10^{-2}	2.33
10^{-3}	3.09
10^{-4}	3.71
10^{-5}	4.26
10^{-6}	4.75
10^{-7}	5.19
10^{-8}	5.62
10^{-9}	5.99



The definition for a two-variable case can be generalized for n variables as follows.

Consider a limit state function $g(X_1, X_2 \dots X_n)$ where the X_i variables are all uncorrelated. The Hasofer-Lind reliability index is defined as follows:

1. Define the set of reduced variables $\{Z_1, Z_2 \dots Z_n\}$ using

$$Z_i = \frac{X_i - \mu_{X_i}}{\sigma_{X_i}} \quad (0.17)$$

2. Redefine the limit state function by expressing it in terms of the reduced variables $\{Z_1, Z_2 \dots Z_n\}$
3. The reliability index is the shortest distance from the origin in the n -dimensional space of reduced variables to the curve described by $g(Z_1, Z_2 \dots Z_n) = 0$.



First-Order Second-Moment Reliability Index

Linear limit state functions

Consider a *linear* limit state function of the form

$$g(X_1, X_2, \dots, X_n) = a_0 + a_1X_1 + a_2X_2 + \dots + a_nX_n = a_0 + \sum_{i=1}^n a_iX_i \quad (0.18)$$

where the a_i terms ($i = 0, 1, 2 \dots n$) are constants and the X_i terms are *uncorrelated* random variables.

If we apply the three-step procedure outlined above for determining the Hasofer-Lind reliability index, we would obtain the following expression for β :

$$\beta = \frac{a_0 + \sum_{i=1}^n a_i\mu_{X_i}}{\sqrt{\sum_{i=1}^n (a_i\sigma_{X_i})^2}} \quad (0.19)$$



Fundusze Europejskie
Wiedza Edukacja Rozwój

Unia Europejska
Europejski Fundusz Społeczny



Observe that the reliability index, β , in Eq. (0.19) depends only on the means and standard deviations of the random variables.

Therefore, this p is called a *second-moment* measure of structural safety because only the first two moments (mean and variance) are required to calculate β .

There is no explicit relationship between β and the type of probability distributions of the random variables.

If the random variables are all normally distributed and uncorrelated, then this formula is *exact* in the sense that p and P_f are related by Eq. (0.16).

Otherwise, Eq. (0.16) provides only an approximate means of relating β to a probability of failure.



EXAMPLE

Consider the simply supported beam shown in Figure.

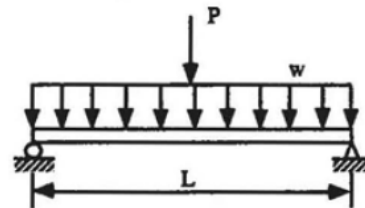

The beam is subjected to a concentrated live load P and a uniformly distributed dead load w .

The loads are random variables.

Assume that P , w , and the yield stress, F_y , are random quantities; the length L and the plastic section modulus Z are assumed to be precisely known (deterministic).

The distribution parameters for P , w , and F_y are given below.



A quantity known as the "bias factor" (denoted by λ) is specified for each of the random variables.

It is defined as the ratio of the mean value of a variable to its nominal value (i.e., the value specified in a standard or code).

The length L is 18 ft, and the plastic section modulus is 80 in^3 .

Nominal (design) value of $w = w_n = 3.0 \text{ k/ft} = 0.25 \text{ k/in}$

Bias factor for $w = \lambda_w = 1.0$

$$\mu_w = \lambda_w w_n = 3.0 \text{ k/ft} = 0.25 \text{ k/in}$$

$$V_w = 10\% \Rightarrow \sigma_w = V_w \mu_w = 0.3 \text{ k/ft} = 0.025 \text{ k/in}$$

Nominal (design) value of $P = p_n = 12.0 \text{ k}$

Bias factor for $P = \lambda_p = 0.85$

$$\mu_p = \lambda_p P_n = 10.2 \text{ k}$$

$$V_p = 11\% \Rightarrow \sigma_p = V_p \mu_p = 1.12 \text{ k}$$



Nominal (design) value of $F_y = f_y = 36$ ksi

Bias factor for $F_y = \lambda_F = 1.12$

$\mu_F = \lambda_F f_y = 40.3$ ksi

$V_F = 11.5\% \Rightarrow \sigma_F = V_F \mu_F = 4.64$ ksi

Calculate the reliability index.

Solution. The limit state function for beam bending can be expressed as

$$g(P, w, F_y) = F_y Z - \frac{PL}{4} - \frac{wL^2}{8}$$

Substituting for L and Z (and converting all units to inches), the limit state function can be rewritten as

$$g(P, w, F_y) = 80F_y - 54P - 5832w \quad [k, in]$$

Since the limit state function is linear, Eq. (0.19) can be used to determine the reliability index β :



$$\begin{aligned}\beta &= \frac{a_0 + \sum_{i=1}^n a_i \mu_{X_i}}{\sqrt{\sum_{i=1}^n (a_i \sigma_{X_i})^2}} = \\ &= \frac{80(40.3) - 54(10.2) - 5832(0.25)}{\sqrt{[(80)(4.640)]^2 + [(-54)(1.12)]^2 + [(-5832)(0.025)]^2}} = \\ &= \frac{1215.2}{403.37} = 3.01\end{aligned}$$

Nonlinear limit state functions

Now consider the case of a *nonlinear* limit state function.

When the function is nonlinear, we can obtain an approximate answer by linearizing the nonlinear function using a Taylor series expansion.



The result is

$$g(X_1, X_2, \dots, X_n) =$$
$$\approx g(x_1^*, x_2^*, \dots, x_n^*) + \sum_{i=1}^n (X_i - x_i^*) \frac{\partial g}{\partial X_i} \Big|_{\text{evaluated at } (x_1^*, x_2^*, \dots, x_n^*)} \quad (0.20)$$

where $(x_1^*, x_2^*, \dots, x_n^*)$ is the point about which the expansion is performed.

One choice for this linearization point is the point corresponding to the mean values of the random variables. Thus Eq. (0.20) becomes

$$g(X_1, X_2, \dots, X_n) =$$
$$\approx g(\mu_{X_1}, \mu_{X_2}, \dots, \mu_{X_n}) + \sum_{i=1}^n (X_i - \mu_{X_i}) \frac{\partial g}{\partial X_i} \Big|_{\text{evaluated at mean values}} \quad (0.21)$$

Since Eq. (0.21) is a linear function of the X_i variables, it can be rewritten to look exactly like Eq. (0.18).

Thus Eq. (0.19) can be used as an approximate solution for the reliability index β .



After some algebraic manipulations, the following expression for β results:

$$\beta = \frac{g(\mu_{X_1}, \mu_{X_2}, \dots, \mu_{X_n})}{\sqrt{\sum_{i=1}^n (a_i \sigma_{X_i})^2}} \quad \text{where} \quad a_i = \left. \frac{\partial g}{\partial X_i} \right|_{\text{evaluated at mean values}} \quad (0.22)$$

The reliability index defined in Eq. (0.22) is called a *first-order second-moment mean value reliability index*.

It is a long name, but the underlying meaning of each part of the name is very important:

First order because we use first-order terms in the Taylor series expansion.

Second moment because only means and variances are needed.

Mean value because the Taylor series expansion is about the mean values.



EXAMPLE

Consider the reinforced concrete beam shown in Figure.

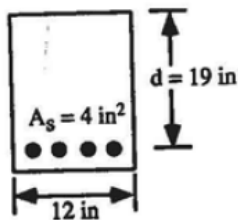

The moment-carrying capacity of the section is calculated using

$$M = A_s f_y \left(d - 0.59 \frac{A_s f_y}{f'_c b} \right) = A_s f_y d - 0.59 \frac{(A_s f_y)^2}{f'_c b}$$

where A_s is the area of steel, f_y is the yield strength of the steel, f'_c is the compressive strength of the concrete, b is the width of the section, and d is the depth of the section.

We want to examine the limit state of exceeding the beam capacity in bending.



The limit state function would be

$$g(A_s, f_y, f'_c, Q) = A_s f_y d - 0.59 \frac{A_s f_y}{f'_c b} Q$$

where Q is the moment (load effect) due to the applied load. The random variables in the problem are Q , f_y , f'_c , and A_s .

The distribution parameters and design parameters are given in Table 5.2, where λ is the bias factor (ratio of mean value to nominal value).

	Mean	Nominal	λ	σ	V
f_y	44 ksi	40 ksi	1.10	4.62 ksi	0.105
A_s	4.08 in²	4 in²	1.02	0.08 in²	0.02
f'_c	3.12 ksi	3 ksi	1.04	0.44 ksi	0.14
Q	2052 k-in	2160 k-in	0.95	246 k-in	0.12

The values of d and b are assumed to be deterministic constants. Calculate the reliability index, β .



Solution. For this problem, the limit state function is nonlinear, so we need to apply Eq.(0.20) or (0.21). The Taylor expansion about the mean values yields the following linear function:

$$g(A_s, f_y, f'_c, Q) \approx \left[\mu_{A_s} \mu_{f_y} d - 0.59 \frac{(\mu_{A_s} \mu_{f_y})^2}{\mu_{f'_c} b} - \mu_Q \right] +$$
$$+(A_s - \mu_{A_s}) \frac{\partial g}{\partial A_s} \Big|_{\text{evaluated at mean values}} +$$
$$+(f_y - \mu_{f_y}) \frac{\partial g}{\partial f_y} \Big|_{\text{evaluated at mean values}} + (f'_c - \mu_{f'_c}) \frac{\partial g}{\partial f'_c} \Big|_{\text{evaluated at mean values}} +$$
$$(Q - \mu_Q) \frac{\partial g}{\partial Q} \Big|_{\text{evaluated at mean values}}$$

To calculate β , the partial derivatives must be determined and the limit state function must be evaluated at the mean values of the random variables:



$$g(\mu_{A_s}, \mu_{f_y}, \mu_{f'_c}, \mu_Q) = \mu_{A_s} \mu_{f_y} \mu_d - 0.59 \frac{(\mu_{A_s} \mu_{f_y})^2}{\mu_{f'_c} b} - \mu_Q = 851.0 \text{ kin}$$

$$a_1 = \left. \frac{\partial g}{\partial A_s} \right|_{\text{mean values}} = \left[f_y d - 0.59 \frac{(2A_s f_y^2)}{f'_c b} \right] \Big|_{\text{mean values}} = 587.1 \text{ k/in}$$

$$a_2 = \left. \frac{\partial g}{\partial f_y} \right|_{\text{mean values}} = \left[A_s d - 0.59 \frac{(2f_y A_s^2)}{f'_c b} \right] \Big|_{\text{mean values}} = 54.44 \text{ in}^3$$

$$a_3 = \left. \frac{\partial g}{\partial f'_c} \right|_{\text{mean values}} = \left[0.59 \frac{(A_s f_y)^2}{(f'_c)^2 b} \right] \Big|_{\text{mean values}} = 162.8 \text{ in}^3$$

$$a_4 = \left. \frac{\partial g}{\partial Q} \right|_{\text{mean values}} = -1 \Big|_{\text{mean values}} = -1$$



Substituting these results into Eq. (0.22), we get

$$\begin{aligned}\beta &= \frac{g(\mu_{A_s}, \mu_{f_y}, \mu_{f'_c}, \mu_Q)}{\sqrt{[(587.1)(\sigma_{A_s})]^2 + [(54.44)(\sigma_{f_y})]^2 + [(162.8)(\sigma_{f'_c})]^2 + [(-1)(\sigma_Q)]^2}} \\ &= \frac{851.0}{\sqrt{[(587.1)(0.08)]^2 + [(54.44)(4.62)]^2 + [(162.8)(0.44)]^2 + [(-1)(246)]^2}} \\ &= \frac{851.0}{362.1} = 2.35\end{aligned}$$

Comments on the First-Order Second-Moment Mean Value Index

The first-order second-moment mean value method is based on approximating nonnormal CDFs of the state variables by normal variables, as shown in Figure for the simple case in which $g(R, Q) = R - Q$.

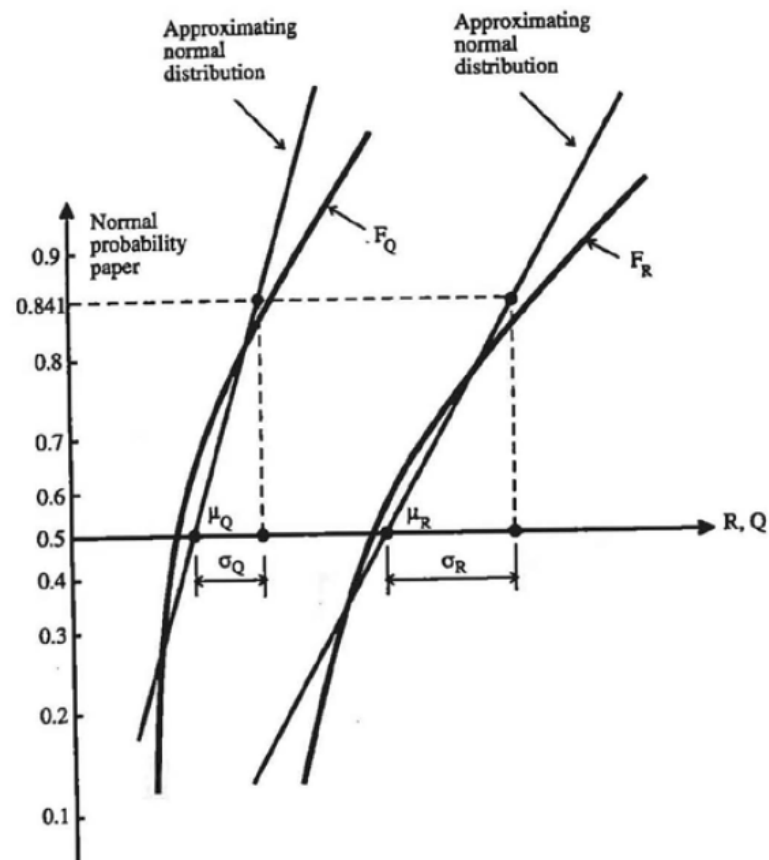

Mean value second-moment formulation

The method has both advantages and disadvantages in structural reliability analysis.



**Fundusze
Europejskie**
Wiedza Edukacja Rozwój

Unia Europejska
Europejski Fundusz Społeczny



Among its advantages,

1. It is easy to use.
2. It does not require knowledge of the distributions of the random variables

Among its disadvantages

1. Results are inaccurate if the tails of the distribution functions cannot be approximated by a normal distribution.
2. There is an invariance problem: the value of the reliability index depends on the specific form of the limit state function.



EXAMPLE. Consider the steel beam shown in Figure.

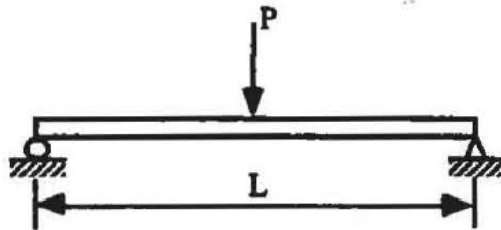

The steel beam is assumed to be compact with parameters Z (plastic modulus) and yield stress f_y .

There are four random variables to consider: P , L , Z , F_y .

It is assumed that the four variables are uncorrelated.

The means and covariance matrix are given as

$$\{\mu_X\} = \begin{Bmatrix} \mu_P \\ \mu_L \\ \mu_Z \\ \mu_{F_y} \end{Bmatrix} = \begin{Bmatrix} 100 \text{ kN} \\ 8 \text{ m} \\ 100 \times 10^{-6} \text{ m}^3 \\ 600 \times 10^3 \text{ kN / m}^2 \end{Bmatrix}$$



$$\{C_x\} = \left\{ \begin{array}{cccc} 4 \text{ kN} & 0 & 0 & 0 \\ 0 & 100 \times 10^{-6} \text{ m}^2 & 0 & 0 \\ 0 & 0 & 400 \times 10^{-12} \text{ m}^6 & 0 \\ 0 & 0 & 0 & 10 \times 10^9 (\text{kN} / \text{m}^2)^2 \end{array} \right\}$$

To begin, consider a limit state function in terms of moments. We can write

$$g_1(Z, F_y, P, L) = ZF_y - \frac{PL}{4}$$

Now recall that the purpose of the limit state function is to define the boundary between the safe and unsafe domains, and the boundary corresponds to $g = 0$.

So if we divide g_1 by a positive quantity (e.g., Z), then we are not changing the boundary or the regions in which the limit state function is positive or negative.



**Fundusze
Europejskie**
Wiedza Edukacja Rozwój

Unia Europejska
Europejski Fundusz Społeczny



Thus an alternative limit state function (with units of stress) would be

$$g_2(Z, F_y, P, L) = F_y - \frac{PL}{4Z} = \frac{g_1(Z, F_y, P, L)}{Z}$$

Since both functions satisfy the requirements for a limit state function, both are valid, and we want to calculate the reliability index for both functions.

Solution. For the function g_1 , which is nonlinear, the calculation of the reliability index is given by Eq. (0.22).

The limit state function is linearized about the means.

The results are



$$g_1 \approx \left[\mu_Z \mu_{F_y} - \frac{\mu_P \mu_L}{4} \right] + \mu_{F_y} (Z - \mu_Z) + \mu_Z (F_y - \mu_{F_y}) - \frac{\mu_L}{4} (P - \mu_P) - \frac{\mu_P}{4} (L - \mu_L)$$
$$\beta = 2.48$$

For g_2 , which is also nonlinear, we use Eq. (0.22) and again linearize about the mean values.

The results are

$$g_1 \approx \left[\mu_{F_y} - \frac{\mu_P \mu_L}{4 \mu_Z} \right] + \frac{\mu_P \mu_L}{4 (\mu_Z)^2} (Z - \mu_Z) + (1) (F_y - \mu_{F_y}) - \frac{\mu_L}{4 \mu_Z} (P - \mu_P) - \frac{\mu_P}{4 \mu_Z} (L - \mu_L)$$
$$\beta = 3.48$$



**Fundusze
Europejskie**
Wiedza Edukacja Rozwój

Unia Europejska
Europejski Fundusz Społeczny



This example clearly demonstrates the "invariance" in the mean value second-moment reliability index.

In this example, the same fundamental limit state forms the basis for both limit state functions.

Therefore, the probability of failure (as reflected by the reliability index) should be the same.