

EXPERIMENT 6 PHOTOPLETHYSMOGRAM MEASUREMENT

6.0 OBJECTIVE

The purpose of this experiment is to help students to learn the non-invasive measurement of vessel volume. The change of diameter of the artery in a finger can be detected by an infrared photocoupler.

Besides, the students can compare the volume of a peripheral vessel before and after exercise.

6.1 PHYSIOLOGICAL PRINCIPLE

Heart is the main role of circulatory system, which is composed by two ventricles and two atria.

Blood in the upper and lower vena cava is low oxygen-contained. It flows into right atrium. Then, right ventricle pumps blood into lungs. In the alveoli of lungs, oxygen exchanges with carbon dioxide. After the high oxygen-contained blood enters left atrium, the blood is pumped into the aorta by left ventricle and distributed to all parts of body by means of arterial system. The smallest vessel in tissue is called capillary.

Capillaries are minute vessels which contains only 5 % of whole circulatory blood. In the 5% blood, oxygen and nutrition must pass through capillary wall to enter to cells. Oppositely, carbon dioxide and waste must come from cells to capillaries. At last, all capillaries converge to veins and by upper and lower vena cava, blood flows back to right atrium. A systemic circulation is now completed.

Arterial system has the function of pressure-storage. Blood will be pumped from heart to arteries, then flows into the small capillaries. The signals of automatic nervous system are able to control the sphincters on minute vessels. It explains why our body can adjust the flow rate of blood. The flow rate in certain organs

changes by the situation of partial area. For example, when the value of PH inside the cells is decreased and the percentage of oxygen becomes lower or when the percentage of carbon dioxide augments, the cells need more blood flow. At this moment, the sphincters on vessels will dilate and allow more blood to flow into those capillaries. The blood distribution of a specific organ is different in rest or in exercise. During exercise, less blood flow into skins and gastrointestinal tracts, but more into the skeletal muscle. Meanwhile, the cardiac output increases.

The volume of blood in capillary varies with the contraction or dilatation of heart. And this can be easily detected by photoplethysmograph. By the way of photoplethysmograph, we can observe the change of blood volume under waveform. After the differentiation of signal by time, the rate of blood flow will be obtained.

6.2 PRINCIPLE OF CIRCUIT DESIGN

1. Block Diagram of Vessel Volume Detection Circuit

Figure 6.1 shows how to use an infrared photocoupler to detect the volume change in the capillaries of fingers and to obtain pulse further. This way of measurement can avoid the interference of light, that's why the infrared technique is considered better than photo-resistors or light-visible photocouplers. The detected signal by an infrared photocoupler should be filtered by a 2nd-order high-pass filter, in order to eliminate the drift voltage due to the tremble of finger or DC biasing voltage of the photocoupler. In fact, it can make sure that the next circuit stage will not operate under saturation. The amplifier circuit is designed to amplify the signal and will make phase shifting. Thus, it avoids the distortion in next detection circuit. Here, a 4th-order low-pass filter is adopted not only to eliminate the interference of power source, but also to avoid the noise of high frequency. After differentiator and amplifier, the amplitude of signal increases. Then, after comparator circuit, a square waveform will be generated. This square wave will trigger monostable multivibrator and becomes a square wave with stable pulse which is synchronized with heartbeat. It is known that human blood pressure and heart

rate will both raise during exercise. When they reach to a certain limit, the peripheral capillaries will be fully enlarged. At this time, no or very little change of vessel volume will be detected.

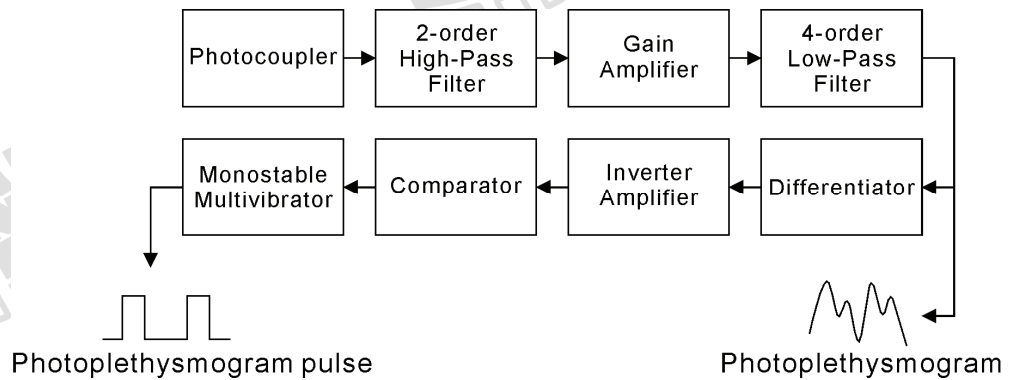

Figure 6.1 Block diagram for measuring vessel volume and heartbeat with a photocoupler.

2. Infrared Photocoupler

A PN junction of a semiconductor is formed by the amalgamation of a P semiconductor doping with P-type material and a semiconductor doping with an N-type material. When the P-type semiconductor is biased by a positive potential and the N-type semiconductor is biased by a negative potential, the corresponding hole and electron carriers will move to the junction. This causes the combination of the hole and electron. But, when the PN junction is operated with a reverse-bias voltage, the electrical charges will move away from the junction. Then, a 'depletion region' is formed due to the absence of the free electrical charges in the junction area. Meanwhile, the minority of carriers in the P- and N-type semiconductors will pass through the depletion region, resulting in a so-called leakage current. In a certain PN junction semiconductor, the layer of the N-type semiconductor is so thin that light beams can pass it, and some electrons will be excited, causing a leakage current. The leakage current is positively proportional to the light intensity. The same principle can be applied to NPN-type transistors, so called phototransistors. In the phototransistor, its base is like a light mask and may receive incident lights. Thus, a collector-emitter current will be generated when there are incident light waves.

The infrared photocoupler consists of an infrared light-emitting diode and a phototransistor. The tissue construction will be altered due to the change in blood flow of capillaries. Therefore, when a subject's skin is in touch with the photocoupler, the intensity of the reflected infrared light will be varied with the blood flow. Although weak, the reflected light signal can be detected by the photocoupler. To reduce the interference of visible lights, a maximum power with wavelength of 880 nm is selected for the diode emitter and the transistor receiver.

A light-emitting diode and a phototransistor are used in the present module. Figure 6.2 shows the emitting wavelength range, emitting angle and pin configuration of the light-emitting diode, while Figure 6.3 demonstrates the receiving wavelength range, receiving angle and pin configuration of the phototransistor. The light-emitting diode is operated with a forward-biased voltage, as shown in Figure 6.4. According to specification of the light-emitting diode, its $V_F = 1.5 \text{ V}$ (max) and $I_F = 40 \text{ mA}$ (max). For safety, one tenth of the rating value is chosen, and then the resistor Z_1 for the current limit will be

$$Z_1 = \frac{(5 - 1.5)V}{4 \text{ mA}} = 1.1 \text{ K}\Omega$$

The phototransistor is operated in common-collector configuration, as shown in Figure 6.4. According to specification of the phototransistor, if its operating point is at $V_{CE} = 2.5 \text{ V}$ and $I_C = 2 \text{ mA}$, the value of $(Z_3 + Z_2)$ for biasing should be

$$Z_3 + Z_2 = \frac{(5 - 2.5)V}{2 \text{ mA}} = 1.25 \text{ K}\Omega$$

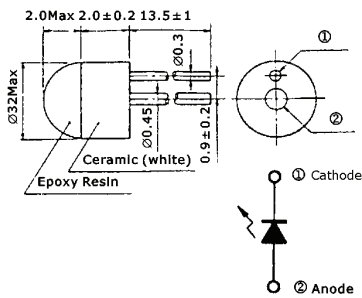
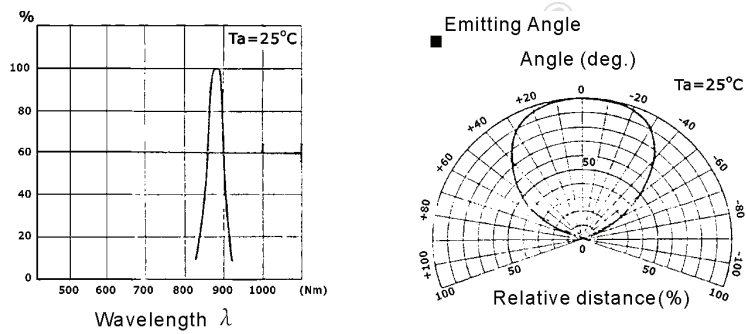

Figure 6.2 Wavelength range, emitting angle and pin configuration of the light-emitting diode.

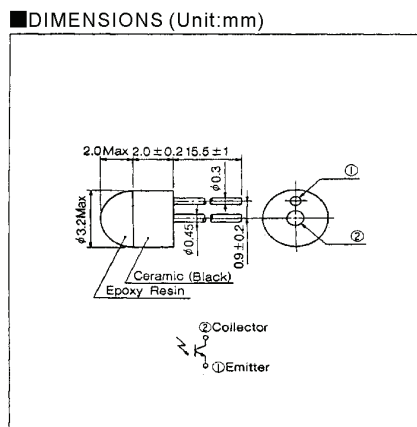
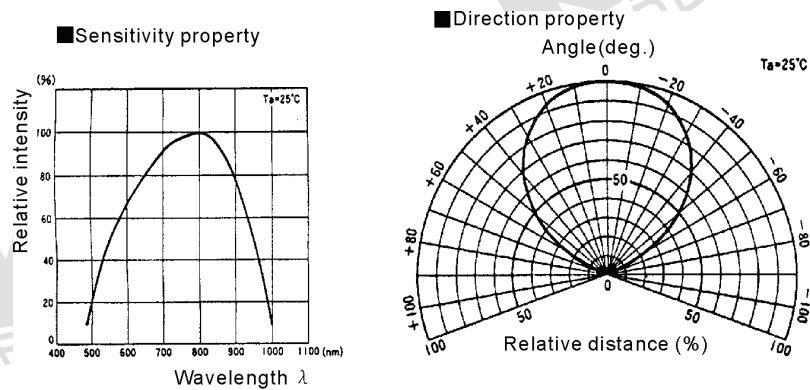

Figure 6.3 Wavelength range, receiving angle and pin configuration of the phototransistor.

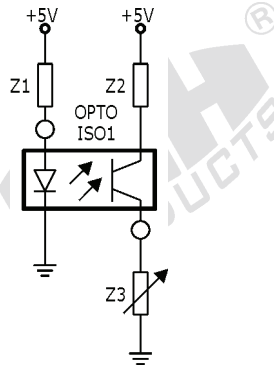

Figure 6.4 Biasing circuit for the photocoupler.

3. High-Pass Filter

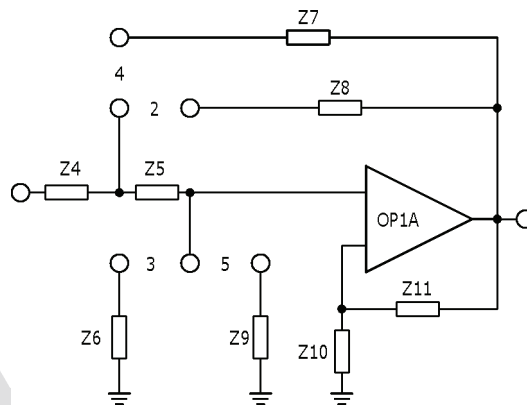

Figure 6.5 High-pass filter.

The purpose of high-pass filter (Figure 6.5) is to remove the voltage drift caused by the shake of finger and DC biasing voltage of the photocoupler, in order to make sure that the next stage circuit won't be in the saturation region and can properly operate. Here, the high-pass filter is a Butterworth filter, and its passband gain A_v and cutoff frequency can be determined with Equations (6.1) and (6.2), respectively:

$$A_v = \frac{Z_{10} + Z_{11}}{Z_{10}} = 1.56 \quad (6.1)$$

$$f_L = \frac{1}{2\pi\sqrt{Z_4 Z_5 Z_6 Z_7}} \quad \text{or} \quad f_L = \frac{1}{2\pi\sqrt{Z_4 Z_5 Z_8 Z_9}} \quad (6.2)$$

4. Gain Amplifier

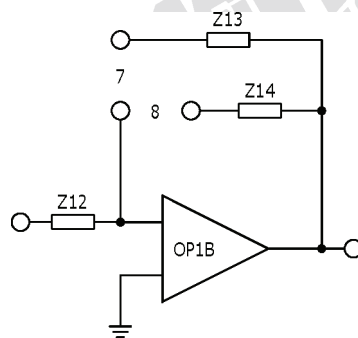
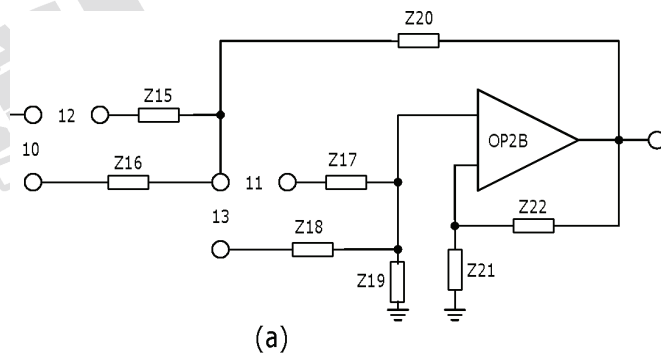

Figure 6.6 Gain amplifier circuit.

Figure 6.6 shows an amplifier which is used to amplify the signal for the next stage circuit. It is one inverting amplifier with a gain of (about) 50 or 100 that can be calculated by Equation (6.3).

$$A_V = \frac{-Z_{13}}{Z_{12}} \quad \text{or} \quad A_V = \frac{-Z_{14}}{Z_{12}} \quad (6.3)$$

5. 4-Order Low-Pass filter



(a)

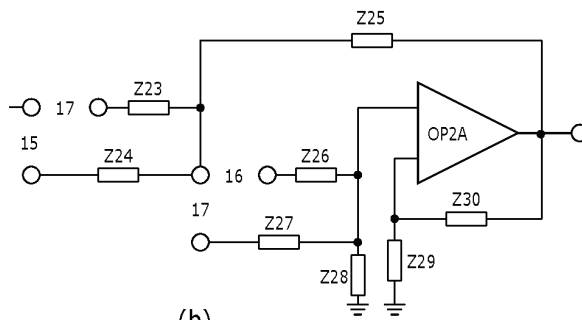

(b)

Figure 6.7 4-order low-pass filter circuit.

The goal of the 4-order low-pass filter (Figure 6.7) is to remove the high-frequency noise from power and from light of fluorescent lamps. In the experiment, the 2-order low-pass filters of Figures 6.7(a) and (b) are Butterworth filters and are connected in series to form a 4-order low-pass filter. Its passband gains, A_{V1} and A_{V2} , and 3dB frequencies, f_{H1} and f_{H2} , can be determined by Equations (6.4), (6.5), (6.6) and (6.7) respectively:

$$A_{V1} = \frac{Z_{21} + Z_{22}}{Z_{21}} = 1.15 \quad (6.4)$$

$$A_{V2} = \frac{Z_{29} + Z_{30}}{Z_{29}} = 2.21 \quad (6.5)$$

$$f_{H1} = \frac{1}{2\pi\sqrt{Z_{15}Z_{17}Z_{19}Z_{20}}} \quad \text{or} \quad f_{H1} = \frac{1}{2\pi\sqrt{Z_{16}Z_{18}Z_{19}Z_{20}}} \quad (6.6)$$

$$f_{H2} = \frac{1}{2\pi\sqrt{Z_{23}Z_{25}Z_{26}Z_{28}}} \quad \text{or} \quad f_{H2} = \frac{1}{2\pi\sqrt{Z_{24}Z_{25}Z_{27}Z_{28}}} \quad (6.7)$$

6. Differentiator

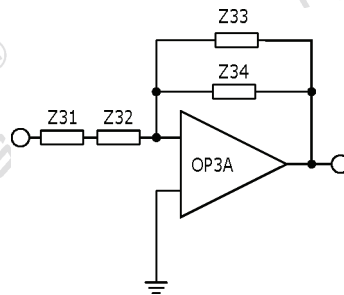

Figure 6.8 Differentiator circuit.

The differentiator (Figure 6.8) can accentuate the volume of change of signal, which is useful for observing the minute change of signal. DC effect may make the operational amplifier operating under saturation region and in this situation the differentiator will not be able to operate normally. So, a high-pass filter circuit is used here to avoid DC voltage shift, after a low-pass filter to remove the high-frequency noise.

7. Amplifier

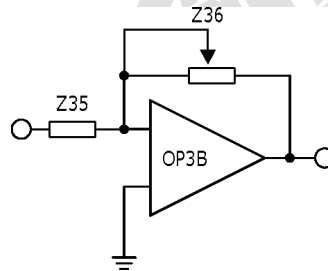

Figure 6.9 Inverting amplifier circuit.

The differentiator circuit will make a phase out of 180° , that's why we need an inverter to recover it, as shown in Figure 6.9.

8. Comparator

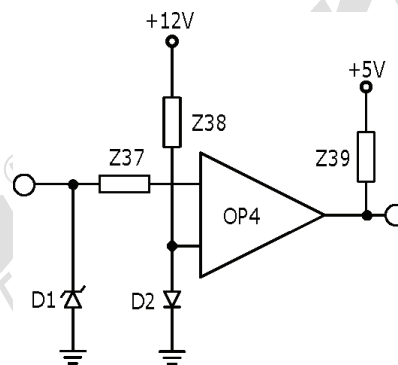

Figure 6.10 Comparator circuit.

The conduction voltage of D_2 is used as a threshold voltage because the closure of aortic valve will cause a reflection waveform and produce wrong trigger. The Zener diode D_1 is used to limit the input voltage of the comparator, it can avoid abnormal action caused by over accumulation of electric charge. In one heartbeat, the comparator can generate only a pulse which is used to trigger the monostable multivibrator.

9. Monostable Multivibrator

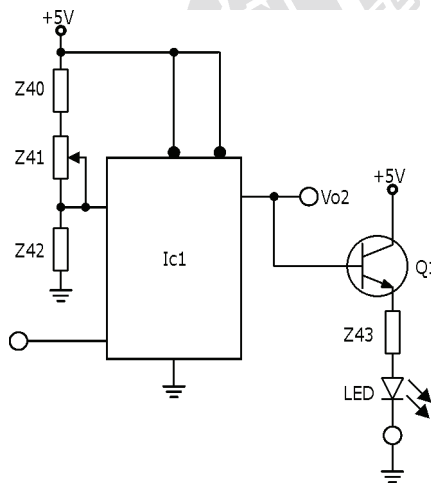

Figure 6.11 Monostable multivibrator circuit.

Figure 6.11 shows the monostable multivibrator which produces a pulse by positive trigger signal. The width of pulse can be controlled by Z_{41} . The LED connected to the multivibrator output will twinkle one time for each heartbeat.

6.3 EQUIPMENT REQUIRED

1. KL-72001 Main Unit
2. KL-75006 Photoplethysmogram Module
3. Digital Storage Oscilloscope
4. Digital Voltmeter (DVM)
5. KL-79102 Infrared Photocoupler Sensor
6. DB9 Cable
7. BNC Cables
8. RS-232 Cable
9. Connecting Wires
10. 10-mm Bridging Plugs
11. Trimmer

6.4 PROCEDURE

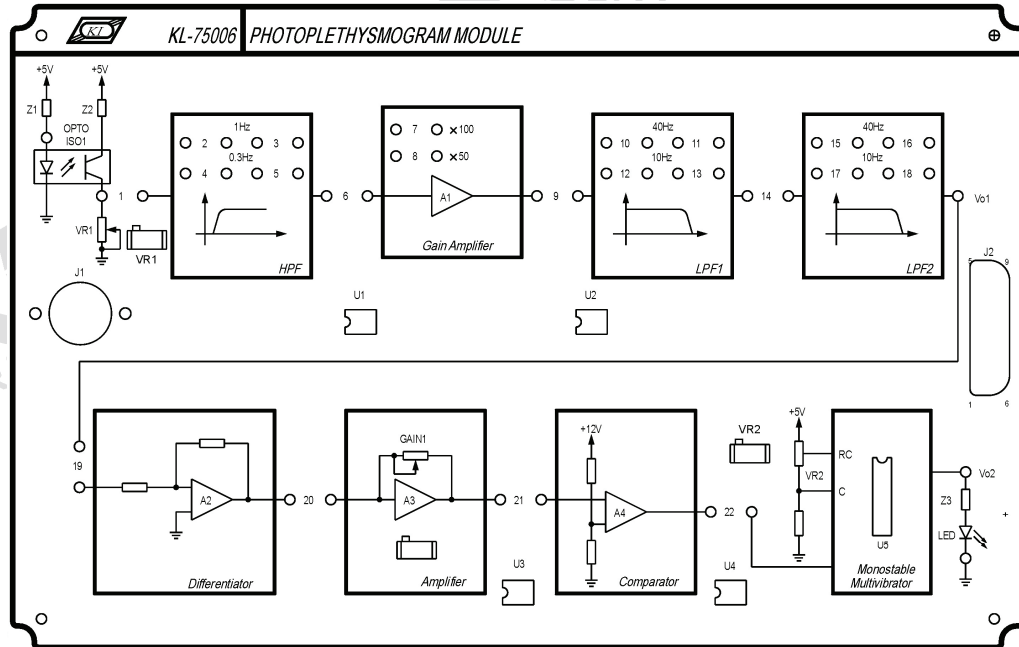

Figure 6.12 Front panel of KL-75006 Photoplethysmogram Module.

A. Calibrating KL-79102 Infrared Photocoupler Sensor

1. Set KL-75006 Photoplethysmogram Module on KL-72001 Main Unit and complete the following connection:

KL-72001 Main Unit			KL-75006 Photoplethysmogram Module		
Section	Area	Terminal	To	Block	Terminal
MODULE OUTPUT	-	9-Pin	→	-	J2

2. Connect KL-79102 Infrared Photocoupler Sensor to the J1 connector on KL-75006 Photoplethysmogram Module.
3. Turn power on.
4. Connect the positive probe of DVM to the emitter of phototransistor, then connect the negative probe to the ground terminal located at the bottom -right of KL-75006 Photoplethysmogram Module.

5. Put KL-79102 Infrared Photocoupler Sensor under normal lighting condition. Adjust VR1 potentiometer so that the output dc voltage of Infrared Sensor (the emitter voltage of phototransistor) V_E indicated by DVM is equal to 1 V.
6. Turn power off and disconnect circuit.

B. Measuring the Characteristics of High-Pass Filter (HPF)

1. Set KL-75006 Photoplethysmogram Module on KL-72001 Main Unit. Complete the following connections:

KL-72001 Main Unit				KL-72001 Main Unit			
Section	Area	Terminal	To	Section	Area	Terminal	
FUNCTION GENERATOR	--	OUTPUT	→	SCOPE ADAPTOR	--	CH1	
SCOPE ADAPTOR	--	CH1 (BNC)	→	CH1 input of oscilloscope			
SCOPE ADAPTOR	--	CH2 (BNC)	→	CH2 input of oscilloscope			

KL-72001 Main Unit				KL-75006 Photoplethysmogram Module	
Section	Area	Terminal	To	Block	Terminal
MODULE OUTPUT	--	9-Pin	→	--	J2
FUNCTION GENERATOR	--	OUTPUT	→	HPF	Input
FUNCTION GENERATOR	--	GND	→	--	Ground (in the bottom-right corner)
SCOPE ADAPTOR	--	CH2	→	HPF	Output

2. On KL-75006 Photoplethysmogram Module, insert bridging plugs in the positions 2 and 3. This sets the cutoff frequency of HPF at 1 Hz.
3. Turn power on.
4. Apply a 1 KHz, 1 Vpp sine signal to the HPF input by adjusting the FREQUENCY and AMPLITUDE knobs of FUNCTION GENERATOR and observe CH1 trace on the oscilloscope screen.
5. Observe HPF output signal displayed on CH2 trace and record the amplitude in Table 6.1.
6. Without changing the amplitude of input sine signal, repeat Steps 4 and 5 for other frequency values listed in Table 6.1.

Table 6.1 Measured output amplitude of HPF.

(a) Cutoff frequency = 1 Hz

Input Freq	1KHz	10Hz	3Hz	2Hz	1Hz	0.9Hz	0.8Hz	0.5Hz	0.1Hz
HPF Output (Vpp)									

(b) Cutoff frequency = 0.3 Hz

Input Freq	1KHz	10Hz	1Hz	0.6Hz	0.5Hz	0.4Hz	0.3Hz	0.2Hz	0.1Hz
HPF Output (Vpp)									

7. According to the recorded data in Table 6.1, plot the characteristic curve of high-pass filter in Table 6.2.

Table 6.2 Characteristic curve of HPF.

(a) Cutoff frequency = 1 Hz

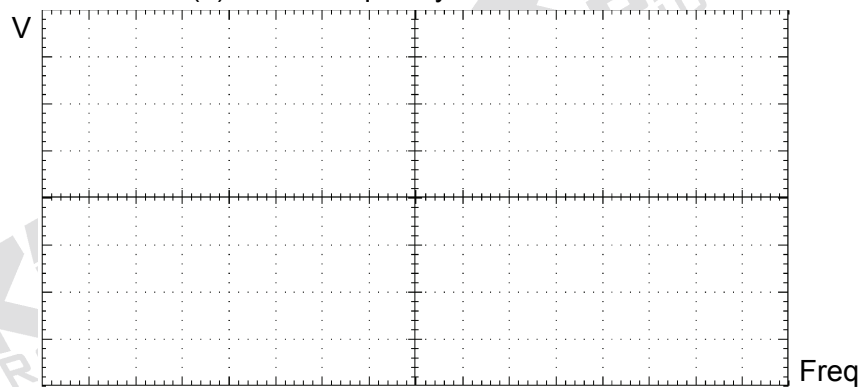

(b) Cutoff frequency = 0.3 Hz

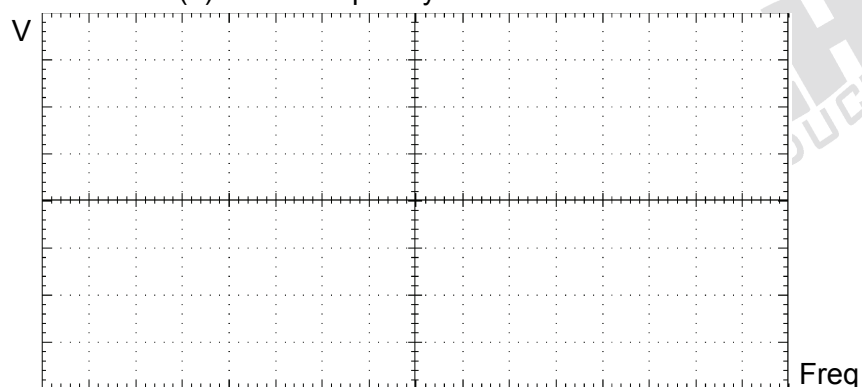

8. Remove the bridging plugs from positions 2 and 3 to positions 4 and 5. This changes the cutoff frequency of HPF from 1 Hz to 0.3 Hz.

9. Repeat Steps 4 through 7.
10. Turn power off and disconnect circuit.

C. Measuring the Characteristics of Gain Amplifier

1. Set KL-75006 Photoplethysmogram Module on KL-72001 Main Unit. Complete the following connections:

KL-72001 Main Unit				KL-72001 Main Unit			
Section	Area	Terminal	To	Section	Area	Terminal	
FUNCTION GENERATOR	--	OUTPUT	→	SCOPE ADAPTOR	--	CH1	
SCOPE ADAPTOR	--	CH1 (BNC)	→	CH1 input of oscilloscope			
SCOPE ADAPTOR	--	CH2 (BNC)	→	CH2 input of oscilloscope			

KL-72001 Main Unit				KL-75006 Photoplethysmogram Module	
Section	Area	Terminal	To	Block	Terminal
MODULE OUTPUT	--	9-Pin	→	--	J2
FUNCTION GENERATOR	--	OUTPUT	→	Gain Amplifier	Input
FUNCTION GENERATOR	--	GND	→	--	Ground (in the bottom right corner)
SCOPE ADAPTOR	--	CH2	→	Gain Amplifier	Output

2. On KL-75006 Photoplethysmogram Module, insert the bridging plug in position 8 (gain = 50).
3. Turn power on.
4. Apply a 100 Hz, 100 mVpp sine signal to Gain Amplifier input by adjusting the FREQUENCY and AMPLITUDE knobs of FUNCTION GENERATOR and observe CH1 trace on the oscilloscope screen.
5. Observe Gain Amplifier output signal displayed on CH2 trace and record the amplitude in Table 6.3.

Table 6.3 Measured output amplitude of Gain Amplifier.

Amplifier Gain Setting	Amplifier Output Voltage (Vpp)
50	
100	

- Remove the bridging plug from position 8 to position 7 (gain = 100). Repeat Steps 4 and 5.
- Turn power off and disconnect circuit.

D. Measuring the Characteristics of 4th-Order Low-Pass Filter

- Set KL-75006 Photoplethysmogram Module on KL-72001 Main Unit. Complete the following connections:

KL-72001 Main Unit				KL-72001 Main Unit			
Section	Area	Terminal	To	Section	Area	Terminal	
FUNCTION GENERATOR	--	OUTPUT	→	SCOPE ADAPTOR	--	CH1	
SCOPE ADAPTOR	Ⓡ	CH1 (BNC)	→	CH1 input of oscilloscope			
SCOPE ADAPTOR	--	CH2 (BNC)	→	CH2 input of oscilloscope			

KL-72001 Main Unit				KL-75006 Photoplethysmogram Module	
Section	Area	Terminal	To	Block	Terminal
MODULE OUTPUT	--	9-Pin	→	--	J2 Ⓡ
FUNCTION GENERATOR	--	OUTPUT	→	LPF1	Input
FUNCTION GENERATOR	--	GND	→	--	Ground (in the bottom-right corner)
SCOPE ADAPTOR	--	CH2	→	LPF2	Output

- On KL-75006 Photoplethysmogram Module, insert bridging plugs in positions 10, 11, 14, 15, and 16. This sets the cutoff frequency of the 4th-order LPF to 40 Hz.
- Turn power on.

4. Apply a 1 Hz, 1 Vpp sine signal to 4th-order LPF input by adjusting the FREQUENCY and AMPLITUDE knobs of FUNCTION GENERATOR and observe CH1 trace on the oscilloscope screen.
5. Observe 4th-order LPF output signal displayed on CH2 trace and record the amplitude in Table 6.4.
6. Without changing the amplitude of input sine signal, repeat Steps 4 and 5 for other frequency values listed in Table 6.4.

Table 6.4 Measured output amplitude of 4th-order LPF.

(a) Cutoff frequency = 40Hz

Input Freq	1Hz	5Hz	10Hz	30Hz	35Hz	40Hz	45Hz	50Hz	100Hz
LPF1 Output (Vpp)									

(b) Cutoff frequency = 10Hz

Input Freq	1Hz	2Hz	3Hz	5Hz	10Hz	15Hz	20Hz	30Hz	40Hz
LPF1 Output (Vpp)									

7. According to the recorded data in Table 6.4, plot the characteristic curve of the 4th-order LPF in Table 6.5.

Table 6.5 Characteristic curve of the 4th-order LPF.

(a) Cutoff frequency = 40Hz

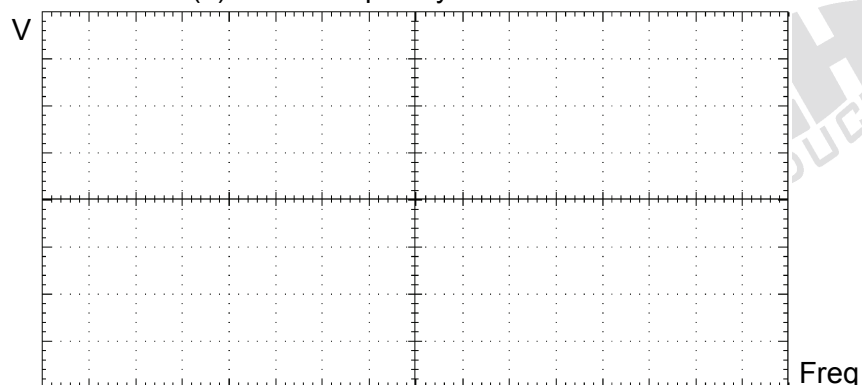

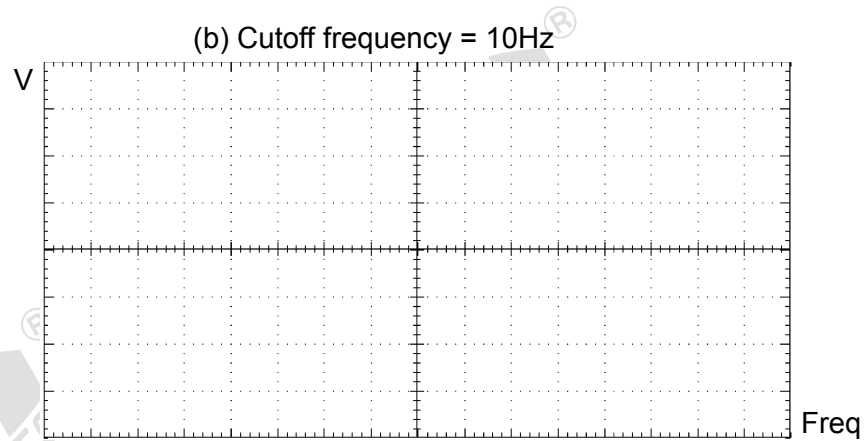

8. Remove the bridging plugs from positions 10, 11, 15, 16 to positions 12, 13, 17, 18. This changes the cutoff frequency of 4th-order LPF from 40 Hz to 10 Hz.
9. Repeat Steps 4 through 7.
10. Turn power off and disconnect circuit.

E. Measuring the Characteristics of Differentiator

1. Set KL-75006 Photoplethysmogram Module on KL-72001 Main Unit. Complete the following connections:

KL-72001 Main Unit				KL-72001 Main Unit		
Section	Area	Terminal	To	Section	Area	Terminal
FUNCTION GENERATOR	–	OUTPUT	→	SCOPE ADAPTOR	--	CH1
SCOPE ADAPTOR	–	CH1 (BNC)	→	CH1 input of oscilloscope		
SCOPE ADAPTOR	–	CH2 (BNC)	→	CH2 input of oscilloscope		

KL-72001 Main Unit			KL-75006 Photoplethysmogram Module		
Section	Area	Terminal	To	Block	Terminal
MODULE OUTPUT	--	9-Pin	→	--	J2
FUNCTION GENERATOR	--	OUTPUT	→	Differentiator	Input
FUNCTION GENERATOR	--	GND	→	--	Ground (at the bottom right corner)
SCOPE ADAPTOR	--	CH2	→	Differentiator	Output

- Turn power on.
- Apply a 1 Hz, 1 Vpp square signal to the Differentiator input by adjusting the FREQUENCY and AMPLITUDE knobs of FUNCTION GENERATOR and observe CH1 trace on the oscilloscope screen.
- Observe the Differentiator output signal displayed on CH2 trace. Record input and output waveforms in Table 6.6.

Table 6.6 Measured input and output waveforms of Differentiator.

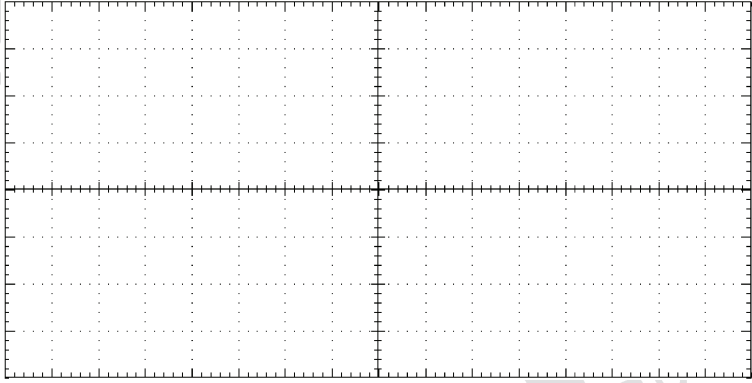
Input Freq	Input (CH1) / Output (CH2)
1Hz	

- Turn power off and disconnect circuit.

F. Measuring the Characteristics of Amplifier

1. Set KL-75006 Photoplethysmogram Module on KL-72001 Main Unit. Complete the following connections:

KL-72001 Main Unit				KL-72001 Main Unit		
Section	Area	Terminal	To	Section	Area	Terminal
FUNCTION GENERATOR	–	OUTPUT	→	SCOPE ADAPTOR	–	CH1
SCOPE ADAPTOR	–	CH1 (BNC)	→	CH1 input of oscilloscope		
SCOPE ADAPTOR	–	CH2 (BNC)	→	CH2 input of oscilloscope		

KL-72001 Main Unit					KL-75006 Photoplethysmogram Module	
Section	Area	Terminal	To	Block	Terminal	
MODULE OUTPUT	–	9-Pin	→	–	J2	
FUNCTION GENERATOR	–	OUTPUT	→	Amplifier	Input	
FUNCTION GENERATOR	–	GND	→	–	Ground (in the bottom right corner)	
SCOPE ADAPTOR	–	CH2	→	Amplifier	Output	

2. Turn power on.
3. Apply a 100 Hz, 100 mVpp sine signal to Amplifier input by adjusting the FREQUENCY and AMPLITUDE knobs of FUNCTION GENERATOR and observe CH1 trace on the oscilloscope screen.
4. Adjust GAIN1 potentiometer to the minimum counterclockwise position (with clicks sound at the end). Record the minimum amplitude of Amplifier output signal displayed on CH2 trace in Table 6.7.
5. Adjust GAIN1 potentiometer clockwise to obtain maximum undistorted output signal. Record the output peak-to-peak voltage in Table 6.7.

Table 6.7 Measured output amplitude of Amplifier.

GAIN1 Position	Amplifier Output Voltage (Vpp)
Minimum counterclockwise	
Maximum undistorted output	

6. Turn power off and disconnect circuit.

G. Measuring the Characteristics of Comparator

1. Set KL-75006 Photoplethysmogram Module on KL-72001 Main Unit. Complete the following connections:

KL-72001 Main Unit				KL-72001 Main Unit		
Section	Area	Terminal	To	Section	Area	Terminal
FUNCTION GENERATOR	--	OUTPUT	→	SCOPE ADAPTOR	--	CH1
SCOPE ADAPTOR	--	CH1 (BNC)	→	CH1 input of oscilloscope		
SCOPE ADAPTOR	--	CH2 (BNC)	→	CH2 input of oscilloscope		

KL-72001 Main Unit				KL-75006 Photoplethysmogram Module	
Section	Area	Terminal	To	Block	Terminal
MODULE OUTPUT	--	9-Pin	→	--	J2
FUNCTION GENERATOR	--	OUTPUT	→	Comparator	Input
FUNCTION GENERATOR	--	GND	→	--	Ground (in the bottom-right corner)
SCOPE ADAPTOR	--	CH2	→	Comparator	Output

3. Turn power on.
4. Apply a 1 KHz, 3 Vpp sine signal to the Comparator input by adjusting the FREQUENCY and AMPLITUDE knobs of FUNCTION GENERATOR and observe CH1 trace on the oscilloscope screen.
5. Record the input and output waveforms in Table 6.8 and determine the threshold voltage V_{TH} of the Comparator by overlapping input and output waveforms.

Table 6.8 Measured input and output waveforms of Comparator.

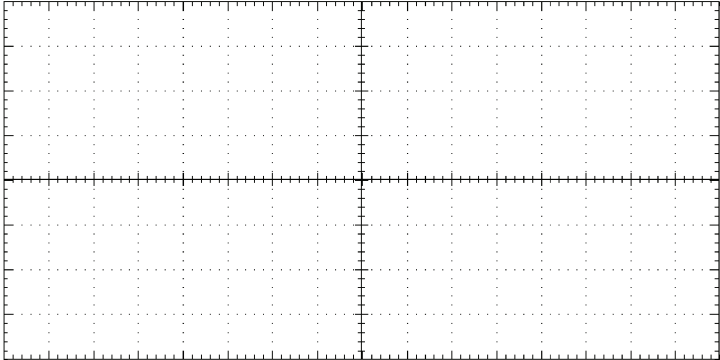
Input (CH1) / Output (CH2)	Threshold Voltage
	$V_{TH} = \underline{\hspace{2cm}} V$

- Turn power off and disconnect circuit.

H. Measuring the Characteristics of Monostable Multivibrator

- Set KL-75006 Photoplethysmogram Module on KL-72001 Main Unit. Complete the following connections:

KL-72001 Main Unit				KL-72001 Main Unit		
Section	Area	Terminal	To	Section	Area	Terminal
SCOPE ADAPTOR	--	CH1 (BNC)	→	CH1 input of the oscilloscope		
SCOPE ADAPTOR	--	CH2 (BNC)	→	CH2 input of the oscilloscope		

KL-72001 Main Unit				KL-75006 Photoplethysmogram Module	
Section	Area	Terminal	To	Block	Terminal
MODULE OUTPUT	--	9-Pin	→	--	J2
FUNCTION GENERATOR	--	OUTPUT	→	Monostable Multivibrator	Input
FUNCTION GENERATOR	--	GND	→	--	Ground (in the bottom right corner)
SCOPE ADAPTOR	--	CH2	→	Monostable Multivibrator	Output (Vo2)

- Turn power on.
- Apply a 1 Hz, 10 Vpp square signal to the Comparator input by adjusting the FREQUENCY and AMPLITUDE knobs of FUNCTION GENERATOR.

4. Adjust VR2 potentiometer to the maximum clockwise position (with clicks sound at the end).
5. Record the input and output waveforms of Monostable Multivibrator in Table 6.9.

Table 6.9 Measured waveforms of Monostable Multivibrator.

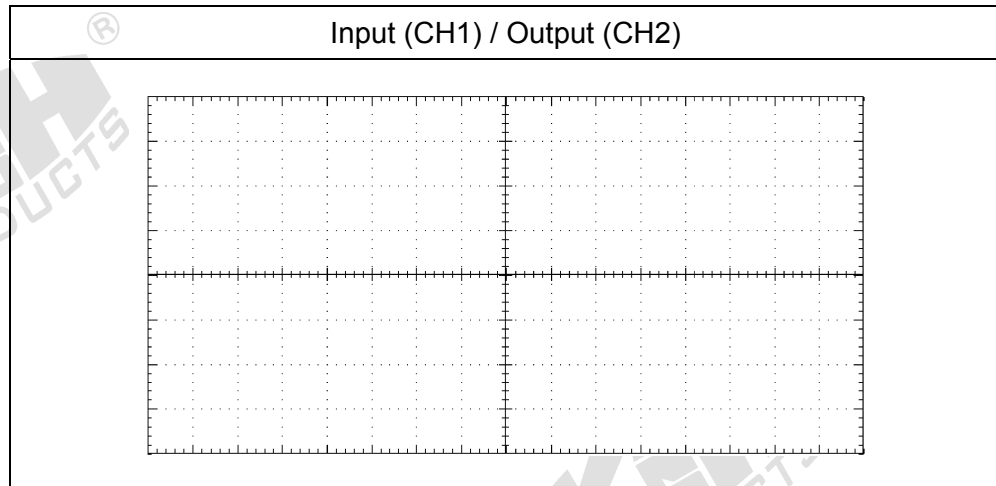

6. Turn power off and disconnect circuit.

I. Human Vessel Volume Measurement using Oscilloscope

1. Set KL-75006 Photoplethysmogram Module on KL-72001 Main Unit. Complete the following connections:

KL-72001 Main Unit				KL-72001 Main Unit		
Section	Area	Terminal	To	Section	Area	Terminal
SCOPE ADAPTOR	--	CH1	→	OUTPUT	PHOTO- PLETHYSMOGRAM	Vo1
SCOPE ADAPTOR	--	CH2	→	OUTPUT	PHOTO- PLETHYSMOGRAM	Vo2
SCOPE ADAPTOR	--	CH1 (BNC)	→	CH1 input of oscilloscope		
SCOPE ADAPTOR	--	CH2 (BNC)	→	CH2 input of oscilloscope		

KL-72001 Main Unit				KL-75006 Photoplethysmogram Module	
Section	Area	Terminal	To	Block	Terminal
MODULE OUTPUT	--	9-Pin	→	--	J2

2. On KL-75006 Photoplethysmogram Module, insert bridging plugs in positions 1, 2 and 3 (HPF cutoff = 1Hz), 6; 8 (gain = 50), 9, 10 and 11 (LPF1 cutoff = 40Hz), 14, 15 and 16 (LPF2 cutoff = 40Hz), 19, 20, 21, and 22.
3. Connect KL-79102 Infrared Photocoupler Sensor to the J1 connector on KL-75006 Photoplethysmogram Module.
4. Turn power on. Select MODULE:KL-75006 (PPG) from the LCD by pressing SELECT button of KL-72001 Main Unit.
5. Make sure that KL-79102 Infrared Photocoupler Sensor has been calibrated and Amplifier GAIN1 potentiometer to a maximum undistorted position. (Refer to Procedures A and F)
6. Place forefinger over the window of KL-79102 Infrared Photocoupler Sensor as shown below.

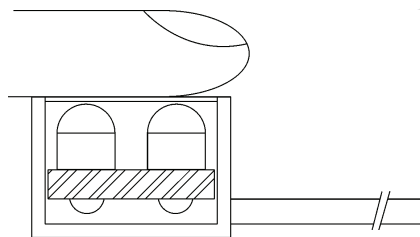

Notes:

- a. During whole experiment, please don't move the finger placed over the sensor. Otherwise, the output waveform will be influenced.
 - b. Adjust Amplifier GAIN1, so the Vo1 frequency is equal to the Vo2 frequency.
7. Set the TIME/DIV control of oscilloscope to 500 ms/div. Record the vessel volume waveform in Table 6.10. And, observe the change in LED state.
 8. Repeat Steps 6 and 7 for other combinations of the gain of Gain Amplifier and cutoff frequencies of HPF, LPF1 and LPF2.
 9. Turn power off and disconnect circuit.

Table 6.10 Measured waveforms of human vessel volume measurement.

Gain Amplifier Setting	HPF Cutoff Freq	LPF1 & 2 Cutoff Freq	Vo1 (CH1) / Vo2 (CH2)
50	1Hz	40Hz 40Hz	
50	1Hz	10Hz 10Hz	
50	0.3Hz	40Hz 40Hz	
50	0.3Hz	10Hz 10Hz	

Table 6.10 (Continued)

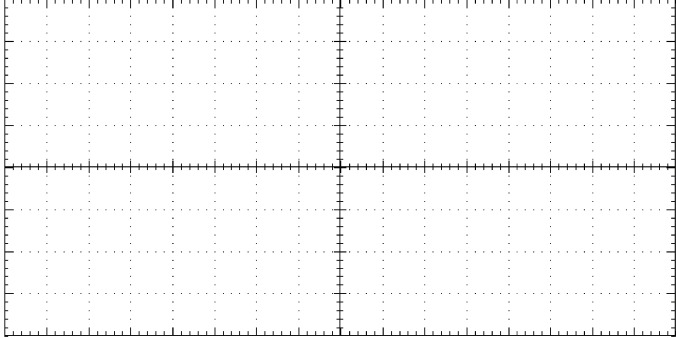
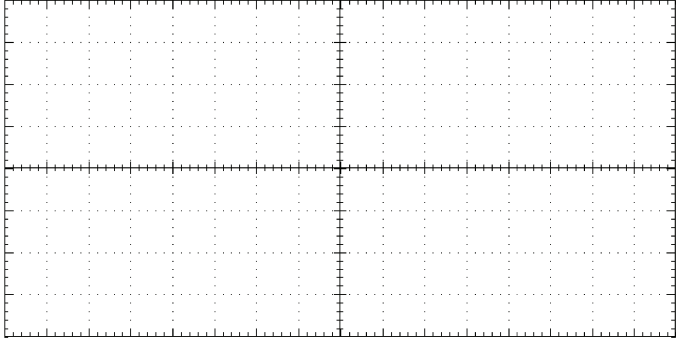
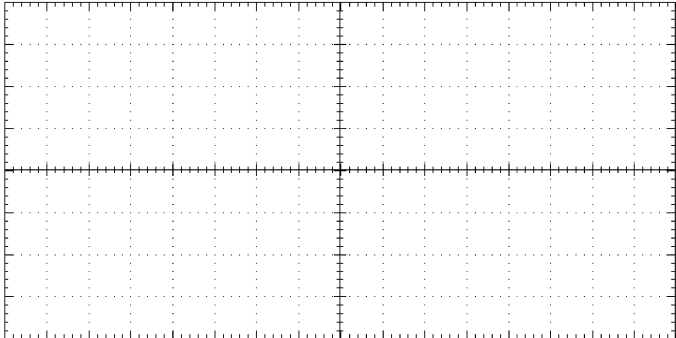
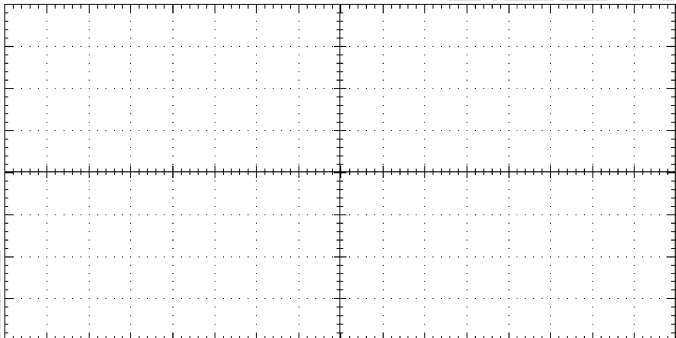
Gain Amplifier Setting	HPF Cutoff Freq	LPF1 & 2 Cutoff Freq	Vo1 (CH1) / Vo2 (CH2)
100	1Hz	40Hz 40Hz	
100	1Hz	10Hz 10Hz	
100	0.3Hz	40Hz 40Hz	
100	0.3Hz	10Hz 10Hz	

J. Human Vessel Volume Measurement using KL-720 Software

1. Set KL-75006 Photoplethysmogram Module on KL-72001 Main Unit and complete the following connection:

KL-72001 Main Unit			KL-75006 Photoplethysmogram Module		
Section	Area	Terminal	To	Block	Terminal
MODULE OUTPUT	--	9-Pin	→	--	J2

2. On KL-75006 Photoplethysmogram Module, insert bridging plugs in positions 1, 2 and 3 (HPF cutoff = 1Hz), 6; 8 (gain = 50), 9, 10 and 11 (LPF1 cutoff = 40Hz), 14, 15 and 16 (LPF2 cutoff = 40Hz), 19, 20, 21, and 22.
3. Connect KL-79102 Infrared Sensor to the J1 connector on KL-75006 Photoplethysmogram Module.
4. Connect the RS-232 OUTPUT connector on KL-72001 Main Unit to the RS-232 port on your computer using RS-232 cable.
5. Turn power on. Select MODULE:KL-75006 (PPG) from the LCD by pressing SELECT button of KL-72001 Main Unit.
6. Make sure KL-79102 Infrared Photocoupler Sensor has been calibrated and Amplifier GAIN1 to a maximum undistorted position. (Refer to Procedures A and F)
7. Place forefinger over the window of KL-79102 Infrared Photocoupler Sensor as shown below.

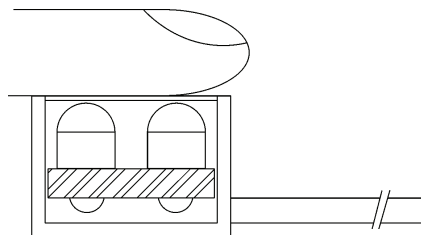

Notes:

- a. During whole experiment, please don't move the forefinger placed over the sensor. Otherwise, the output waveform will be influenced.
 - b. Adjust the Amplifier GAIN1, so the Vo1 frequency is equal to the Vo2 frequency.
8. Boot the computer.

- Execute KL-720 program. The KL-720 Biomedical Measurement System window appears as shown below.

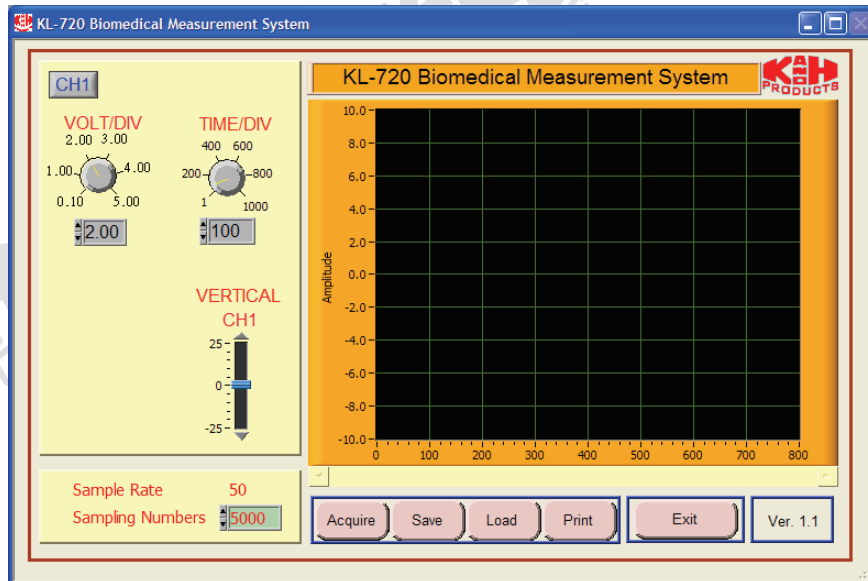

Note: If the message “time out, please check the COM port was connected the device” appears, check the connection and setup of the RS-232 port.

- Click the Acquire button. The system begins to acquire the measured data via RS-232 port and shows the waveforms in KL-75006 Photoplethysmogram windows. It should look like this:

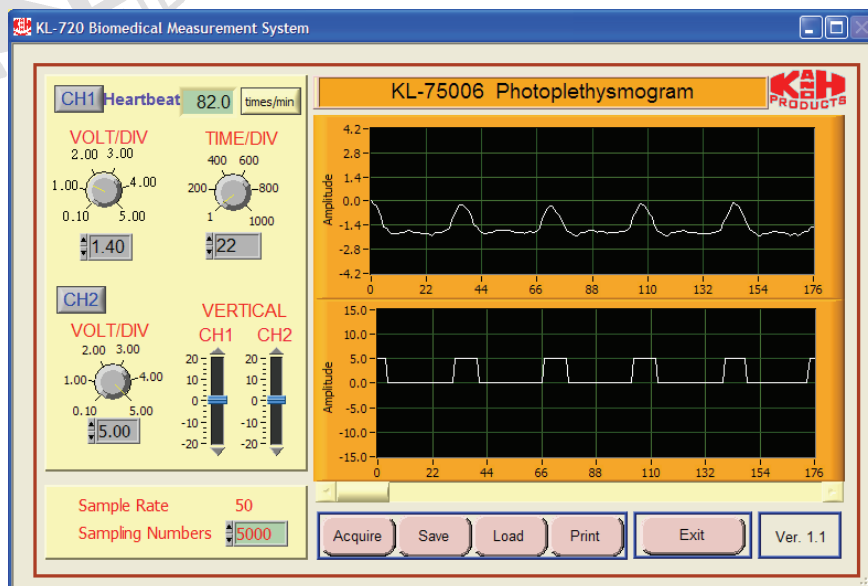

Note: If the message “time out, please check the COM port was connected the device” appears, check the connection and RS-232 port.

11. Adjust the VOLT/DIV and TIME/DIV knobs, so the signals can be read accurately.
12. Save the waveform data on disk, and observe the change in LED state.
13. Exit KL-720 Biomedical Measurement System, turn power off and disconnect circuit.

KAH[®]
PRODUCTS

KAH[®]
PRODUCTS

KAH[®]
PRODUCTS

KAH[®]
PRODUCTS

KAH[®]
PRODUCTS